



Environmental Protection Department

Contract No. HY/2012/06

**Widening of Fanling Highway
- Tai Hang to Wo Hop Shek
Interchange**

**Monthly EM&A Report
For January 2017**

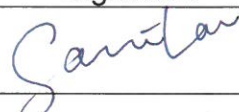
[2/2017]

	Name	Signature
Prepared & Checked:	Sammi Lam	
Reviewed & Approved:	Y W Fung	

Version:	Rev. 0	Date: 13 February 2017
Disclaimer		
<p>This report is prepared for Environmental Protection Department and is given for its sole benefit in relation to and pursuant to Contract No. HY/2012/06 and may not be disclosed to, quoted to or relied upon by any person other than Environmental Protection Department without our prior written consent. No person (other than Environmental Protection Department) into whose possession a copy of this report comes may rely on this report without our express written consent and Environmental Protection Department may not rely on it for any purpose other than as described above.</p>		

<p>AECOM Asia Co. Ltd. 15/F, Grand Central Plaza, Tower 1, 138 Shatin Rural Committee Road, Shatin, NT, Hong Kong Tel: (852) 3922 9000 Fax: (852) 2317 7609 www.aecom.com</p>

Hyder-Arup-Black & Veatch Joint Venture
c/o Arcadis
20/F, AXA Tower, Landmark East,
100 How Ming Street,
Kwun Tong, Hong Kong
Attn: Mr. James Penny

Your Reference

Our Reference

JFP/EC/ST/pl/T329380/22
.05/L-0157

20/F AIA Kowloon Tower
Landmark East
100 How Ming Street
Kwun Tong
Kowloon
Hong Kong

T +852 2828 5757
F +852 2827 1823
mottmac.hk

Environmental Monitoring and Audit (EM&A) for Widening of Tolo Highway/Fanling Highway between Island House Interchange and Fanling Stage 2 (between Tai Hang to Wo Hop Shek Interchange)
Environmental Permit No. EP-324/2008/D Condition 3.3 – Submission of Monthly EM&A Report – January 2017 for the portion of Stage 2 works under Contract No. HY/2012/06

13 February 2017

By Fax (2805 5028) & Hand

We refer to the revised Monthly EM&A Report – January 2017 received on 13 February 2017 submitted by the Environmental Team via email. Pursuant to Environmental Permit Condition 3.3, I hereby verify the Monthly EM&A Report – January 2017 (Rev. 0) for the portion of works under Stage 2 of the captioned Project which is managed under Contract No. HY/2012/06.

Yours faithfully
for MOTT MACDONALD HONG KONG LIMITED



Steven Tang
Independent Environmental Checker

c.c.
HyD
AECOM

Mr. Chung Lok Chin
Mr. Y W Fung

By Fax (2714 5198)
By Fax (2891 0305)

TABLE OF CONTENTS

	Page
EXECUTIVE SUMMARY	3
1 INTRODUCTION	5
1.1 Background	5
1.2 Scope of Report	6
1.3 Project Organization	6
1.4 Summary of Construction Works	6
1.5 Summary of EM&A Programme Requirements	7
2 AIR QUALITY MONITORING	8
2.1 Monitoring Requirements	8
2.2 Monitoring Equipment	8
2.3 Monitoring Locations	8
2.4 Monitoring Parameters and Frequency	8
2.5 Monitoring Methodology	9
2.6 Monitoring Schedule for the Reporting period	10
2.7 Results and Observations	11
3 NOISE MONITORING	12
3.1 Monitoring Requirements	12
3.2 Monitoring Equipment	12
3.3 Monitoring Locations	12
3.4 Monitoring Parameters and Frequency	12
3.5 Monitoring Methodology	13
3.6 Monitoring Schedule for the Reporting period	13
3.7 Monitoring Results	13
4 ENVIRONMENTAL SITE INSPECTION AND AUDIT	15
4.1 Site Inspection	15
4.2 Advice on the Solid and Liquid Waste Management Status	17
4.3 Environmental Licenses and Permits	17
4.4 Implementation Status of Environmental Mitigation Measures	18
4.5 Summary of Exceedances of the Environmental Quality Performance Limit	19
4.6 Summary of Complaints, Notification of Summons and Successful Prosecutions	19
5 FUTURE KEY ISSUES	20
5.1 Construction Programme for the Coming Months	20
5.2 Key Issues for the Coming Month	20
5.3 Monitoring Schedule for the Coming Month	20
6 CONCLUSIONS AND RECOMMENDATIONS	21
6.1 Conclusions	21
6.2 Recommendations	21

List of Tables

Table 1.1	Contact Information of Key Personnel
Table 2.1	Air Quality Monitoring Equipment
Table 2.2	Locations of Impact Air Quality Monitoring Station
Table 2.3	Air Quality Monitoring Parameters, Frequency and Duration
Table 2.4	Summary of 1-hour TSP Monitoring Results in the Reporting Period
Table 2.5	Summary of 24-hour TSP Monitoring Results in the Reporting Period
Table 3.1	Noise Monitoring Equipment
Table 3.2	Locations of Impact Noise Monitoring Stations
Table 3.3	Noise Monitoring Parameters, Frequency and Duration
Table 3.4	Summary of Construction Noise Monitoring Results in the Reporting Period
Table 4.1	Summary of Waste Flow Table
Table 4.2	Summary of Environmental Licensing and Permit Status

Figures

Figure 1.1	General Project Layout Plan
Figure 1.2a-b	Locations of Monitoring Station
Figure 4.1	Environmental Complaint Handling Procedures

List of Appendices

Appendix A	Project Organization Structure
Appendix B	Construction Programme
Appendix C	Implementation Schedule of Environmental Mitigation Measures (EMIS)
Appendix D	Summary of Action and Limit Levels
Appendix E	Calibration Certificates of Monitoring Equipments
Appendix F	EM&A Monitoring Schedules
Appendix G	Impact Air Quality Monitoring Results and their Graphical Presentation
Appendix H	Meteorological Data for the Reporting period
Appendix I	Impact Daytime Construction Noise Monitoring Results and their Graphical Presentation
Appendix J	Event Action Plan
Appendix K	Site Inspection Summaries
Appendix L	Statistics on Complaints, Notifications of Summons and Successful Prosecutions

EXECUTIVE SUMMARY

The proposed widening of Tolo Highway and Fanling Highway between Island House Interchange and Fanling (the Project) is a Designated Project under the Environmental Impact Assessment Ordinance (Cap. 499) (EIAO). An Environmental Impact Assessment (EIA) Report (the approved EIA Report) together with an Environmental Monitoring and Audit (EM&A) Manual (the approved EM&A Manual) were completed and approved under the EIAO on 14 July 2000 (Register Number: EIA-043/2000).

The objective of the Project “Widening of Tolo Highway / Fanling Highway between Island House Interchange and Fanling” is to widen Tolo Highway and Fanling Highway to dual 4-lane carriageway in order to alleviate the current traffic congestion problems and to cope with the increasing transport demands to and from the urban areas and also cross boundary traffic.

The Project is a designated project and governed by an Environmental Permit (EP-324/2008) issued by the EPD on 23 December 2008. Subsequently, the EPD issued Variation of Environmental Permits of EP-324/2008/A, EP-324/2008/B and EP-324/2008/C on 31 January 2012, 17 March 2014 and 27 March 2015 respectively. The current valid VEP was applied on 19 August 2015 and the VEP (EP-324/2008/D) was subsequently granted on 27 August 2015.

The construction works for this Project are delivered in 2 stages i.e. Stage 1 (between Island House Interchange and Tai Hang) and Stage 2 (between Tai Hang and Wo Hop Shek Interchange). Stage 2 would be implemented under two works contracts. Contract No. HY2012/06 “Widening of Fanling Highway – Tai Hang to Wo Hop Shek Interchange” and the entrusted portion to CEDD under Contract No. CV/2012/09 “Liantang/Heung Yuen Wai Boundary Control Point Site Formation and Infrastructure Works – Contract 3”. This report focuses on Contract No. HY2012/06 “Widening of Fanling Highway – Tai Hang to Wo Hop Shek Interchange” in Stage 2 of the Project only.

Pursuant to the EP (EP-324/2008/D) Condition 2.7, the Capture Survey Trip Report for Ma Wat River Northern Meander (Version 2) for the Project was submitted on 24 December 2013 by the Environmental Team (ET) and verified by the Independent Environmental Checker (IEC) on 6 January 2014.

The construction phase of the Contract under the EP and the Environmental Monitoring and Audit (EM&A) programme of the contract commenced on 21 November 2013. The impact environmental monitoring and audit includes air quality and noise monitoring.

This report documents the findings of EM&A works conducted in the period between 1 and 31 January 2017. As informed by the Contractor, construction activities in the reporting period were:

- Site clearance
- Ground investigation
- Pipe laying
- Retaining wall construction
- Noise Barrier
- Excavation
- Backfilling
- Drainage
- Temporary bridge construction
- House Construction
- Foot Bridge demolition
- Bridge construction
- Piling

Reporting Change

There was no reporting change required in the reporting period.

Breaches of Action and Limit Levels for Air Quality

No exceedance of Action and Limit Level was recorded for 1-hour and 24-hour TSP monitoring in the reporting period.

Breaches of Action and Limit Levels for Noise

No Action or Limit Level exceedance of construction noise was recorded in the reporting month. No noise complaints related to 0700 – 1900 hours on normal weekdays was received and followed by Environmental Team in the reporting month.

Complaint, Notification of Summons and Successful Prosecution

One (1) air-related complaint was received on 13 January 2017 and followed up by the Environmental Team in the reporting month. The details of the complaint are described in Section 4.6.4 and the full complaint investigation report is annexed in Appendix M.

No notification of summons and successful prosecution was received in the reporting period.

Future Key Issues

Key issues to be considered in the coming month include:

- Properly store and label oils and chemicals on site;
- Chemical, chemical waste and waste management;
- Collection of construction waste should be carried out regularly;
- Properly maintain all drainage facilities and wheel washing facilities on site;
- Exposed slopes should be covered up properly if no temporary work will be conducted;
- Quieter powered mechanical equipment should be used;
- Suppress dust generated from excavation activities and haul road traffic; and
- Tree protective measures for all retained trees should be well maintained.

1 INTRODUCTION

1.1 Background

- 1.1.1. Tolo Highway and Fanling Highway are the expressways in the North East New Territories (NENT) connecting Sha Tin, Tai Po and Fanling. These highways form a vital part of the strategic Route 9, which links Hong Kong Island to the boundary at Shenzhen. At present, this section of Route 9 is a dual 3-lane carriageway. However, at several major interchanges along this section of Route 9, the highway is a dual-2 lane carriageway only. Severe congestion is a frequent occurrence during the peak periods, particularly in the Kowloon-bound direction.
- 1.1.2. The objective of the Project “Widening of Tolo Highway / Fanling Highway between Island House Interchange and Fanling” is to widen Tolo Highway and Fanling Highway to dual 4-lane carriageway in order to alleviate the current traffic congestion problems and to cope with the increasing transport demands to and from the urban areas and also cross boundary traffic.
- 1.1.3. The Project is a designated project and governed by an Environmental Permit (EP-324/2008) issued by the EPD on 23 December 2008. Subsequently, the EPD issued Variation of Environmental Permits of EP-324/2008/A, EP-324/2008/B and EP-324/2008/C on 31 January 2012, 17 March 2014 and 27 March 2015 respectively. The current valid VEP was applied on 19 August 2015 and the VEP (EP-324/2008/D) was subsequently granted on 27 August 2015.
- 1.1.4. The scope of the Project comprises mainly:-
- (i) Widening of a 5.7 km section of Tolo Highway and 3.0 km section of Fanling Highway between Island House Interchange and Wo Hop Shek Interchange from the existing dual 3-lane to dual 4-lane, including construction of new vehicular bridges;
 - (ii) Widening of interchange sections at Island House Interchange, Tai Po North Interchange, and Lam Kam Road Interchange from dual 2-lane to dual 3-lane, except Sha Tin bound carriageway at Tai Po North Interchange, which is widened from 3-lane to 4-lane, including realignment of various slip roads;
 - (iii) Modification and reconstruction of highways, vehicular bridges, underpasses and footbridges.
- 1.1.5. The construction works for this Project will be delivered in 2 stages i.e. Stage 1 (between Island House Interchange and Tai Hang) and Stage 2 (between Tai Hang and Wo Hop Shek Interchange). Stage 2 would be implemented under two works contracts. Contract No. HY/2012/06 “Widening of Fanling Highway – Tai Hang to Wo Hop Shek Interchange” and the entrusted portion to CEDD under Contract No. CV/2012/09 “Liantang/Heung Yuen Wai Boundary Control Point Site Formation and Infrastructure Works – Contract 3”. This report focuses on Contract No. HY2012/06 “Widening of Fanling Highway – Tai Hang to Wo Hop Shek Interchange” in Stage 2 of the Project only.
- 1.1.6. Hyder-Arup-Black and Veatch Joint Venture (HABVJV) are appointed by Highways Department (HyD) as the consultants for the design and construction assignment for the Tolo project under Agreement No. CE 58/2000 Supplementary Agreement No. 3 (SA3) (i.e. the Engineer for the Contract).
- 1.1.7. China State Construction Engineering (Hong Kong) Ltd. (CSHK) was commissioned as the Contractor of the Contract.
- 1.1.8. AECOM Asia Co. Ltd. was commissioned by China State Construction Engineering (Hong Kong) Limited as the Environmental Team (ET) to undertake the Environmental Monitoring and Audit (EM&A) works for the Contract and Mott MacDonald Hong Kong Ltd. acts as the Independent Environmental Checker (IEC) for the Contract.
- 1.1.9. The construction phase of the Contract under the EP commenced on 21 November 2013.
- 1.1.10. According to the updated EM&A Manual of Stage 2 of the Project, there is a need of an EM&A programme including air quality and noise monitoring. The EM&A programme for Stage 2 of the Project commenced on 21 November 2013.

1.2 Scope of Report

1.2.1 This is the thirty-ninth monthly EM&A Report under the Contract No. HY/2012/06 “Widening of Fanling Highway – Tai Hang to Wo Hop Shek Interchange. This report presents a summary of the environmental monitoring and audit works, list of activities and mitigation measures proposed by the ET for the Contract in January 2017.

1.3 Project Organization

1.3.1 The project organization structure is shown in Appendix A. The key personnel contact names and numbers are summarized in Table 1.1.

Table 1.1 Contact Information of Key Personnel

Party	Position	Name	Telephone	Fax
ER (Hyder-Arup-Black & Veatch Joint Venture)	Chief Resident Engineer	Edwin Chung	6115 0818	2638 0950
IEC (Mott MacDonald Hong Kong Limited)	Independent Environmental Checker	Steven Tang	2828 5920	2827 1823
Contractor (China State Construction Engineering (Hong Kong) Limited)	Environmental Officer	Michael Tsang	9277 4956	2672 2501
		C C Chow	9679 6315	2672 2501
ET (AECOM Asia Company Limited)	ET Leader	Y W Fung	3922 9393	3922 9797

1.4 Summary of Construction Works

1.4.1 The construction phase for the Contract under the EP commenced on 21 November 2013.

1.4.2 Details of the construction works carried out by the Contractor in this reporting period are listed below:

- Site clearance
- Ground investigation
- Pipe laying
- Retaining wall construction
- Noise Barrier
- Excavation
- Backfilling
- Drainage
- Temporary bridge construction
- House Construction
- Foot Bridge demolition
- Bridge construction

- Piling

1.4.3 The Construction Programme is shown in Appendix B.

1.4.4 The general layout plan of the Project site showing the contract areas is shown in Figure 1.1.

1.4.5 The environmental mitigation measures implementation schedule are presented in Appendix C.

1.5 Summary of EM&A Programme Requirements

1.5.1 The EM&A programme required environmental monitoring for air quality, noise and environmental site inspections for air quality, water quality, noise, waste management, ecology, and landscape and visual impact. The EM&A requirements for each parameter described in the following sections include:-

- All monitoring parameters;
- Monitoring schedules for the reporting period and forthcoming months;
- Action and Limit levels for all environmental parameters;
- Event / Action Plan;
- Environmental mitigation measures, as recommended in the Project EIA study final report; and
- Environmental requirement in contract documents.

2 AIR QUALITY MONITORING

2.1 Monitoring Requirements

2.1.1 In accordance with the updated EM&A Manual, baseline 1-hour and 24-hour TSP levels at one air quality monitoring station was established. Impact 1-hour TSP monitoring was conducted for at least three times every 6 days, while impact 24-hour TSP monitoring was carried out for at least once every 6 days. The Action and Limit level of the air quality monitoring is provided in Appendix D.

2.2 Monitoring Equipment

2.2.1 24-hour TSP air quality monitoring was performed using High Volume Sampler (HVS) located at each designated monitoring station. The HVS meets all the requirements of the updated EM&A Manual. Portable direct reading dust meters were used to carry out the 1-hour TSP monitoring. Brand and model of the equipment is given in Table 2.1.

Table 2.1 Air Quality Monitoring Equipment

Equipment	Brand and Model
Portable direct reading dust meter (1-hour TSP)	Sibata Digital Dust Monitor (Model No. LD-3)
High Volume Sampler (24-hour TSP)	Tisch Total Suspended Particulate Mass Flow Controlled High Volume Air Sampler (Model No. TE-5170)

2.3 Monitoring Locations

2.3.1 The monitoring station was set up at the proposed location in accordance with updated EM&A Manual. Table 2.2 describes details of the monitoring station. The locations are shown in Figure 1.2a.

Table 2.2 Locations of Impact Air Quality Monitoring Station

Location	Monitoring Station
AM2 (SR2)	Fanling Government Secondary School

2.4 Monitoring Parameters and Frequency

2.4.1 Table 2.3 summarizes the monitoring parameters, frequency and duration of impact TSP monitoring.

Table 2.3 Air Quality Monitoring Parameters and Frequency

Parameter	Frequency
24-hour TSP	Once every 6 days
1-hour TSP	3 times every 6 days while the highest dust impact was expected

2.5 Monitoring Methodology

2.5.1 24-hour TSP Monitoring

- (a) The HVS was installed in the vicinity of the air sensitive receivers. The following criteria were considered in the installation of the HVS.
- (i) A horizontal platform with appropriate support to secure the sampler against gusty wind was provided.
 - (ii) The distance between the HVS and any obstacles, such as buildings, was at least twice the height that the obstacle protrudes above the HVS.
 - (iii) A minimum of 2 meters separation from walls, parapets and penthouse for rooftop sampler.
 - (iv) A minimum of 2 meters separation from any supporting structure, measured horizontally.
 - (v) No furnace or incinerator flues nearby.
 - (vi) Airflow around the sampler was unrestricted.
 - (vii) Permission was obtained to set up the samplers and access to the monitoring stations.
 - (viii) A secured supply of electricity was obtained to operate the samplers.
 - (ix) The sampler was located more than 20 meters from any dripline.
 - (x) Any wire fence and gate, required to protect the sampler, did not obstruct the monitoring process.
 - (xi) Flow control accuracy was kept within $\pm 2.5\%$ deviation over 24-hour sampling period.
- (b) Preparation of Filter Papers
- (i) Glass fibre filters, G810 were labelled and sufficient filters that were clean and without pinholes were selected.
 - (ii) All filters were equilibrated in the conditioning environment for 24 hours before weighing. The conditioning environment temperature was around 25 °C and not variable by more than ± 3 °C; the relative humidity (RH) was < 50% and not variable by more than $\pm 5\%$. A convenient working RH was 40%.
 - (iii) All filter papers were prepared and analysed by ALS Technichem (HK) Pty Ltd., which is a HOKLAS accredited laboratory and has comprehensive quality assurance and quality control programmes.
- (c) Field Monitoring
- (i) The power supply was checked to ensure the HVS works properly.
 - (ii) The filter holder and the area surrounding the filter were cleaned.
 - (iii) The filter holder was removed by loosening the four bolts and a new filter, with stamped number upward, on a supporting screen was aligned carefully.
 - (iv) The filter was properly aligned on the screen so that the gasket formed an airtight seal on the outer edges of the filter.
 - (v) The swing bolts were fastened to hold the filter holder down to the frame. The pressure applied was sufficient to avoid air leakage at the edges.
 - (vi) Then the shelter lid was closed and was secured with the aluminum strip.
 - (vii) The HVS was warmed-up for about 5 minutes to establish run-temperature conditions.
 - (viii) A new flow rate record sheet was set into the flow recorder.
 - (ix) On site temperature and atmospheric pressure readings were taken and the flow rate of the HVS was checked and adjusted at around 1.1 m³/min, and complied with the range specified in the updated EM&A Manual (i.e. 0.6-1.7 m³/min).
 - (x) The programmable digital timer was set for a sampling period of 24 hrs, and the starting time, weather condition and the filter number were recorded.
 - (xi) The initial elapsed time was recorded.
 - (xii) At the end of sampling, on site temperature and atmospheric pressure readings were taken and the final flow rate of the HVS was checked and recorded.
 - (xiii) The final elapsed time was recorded.

- (xiv) The sampled filter was removed carefully and folded in half length so that only surfaces with collected particulate matter were in contact.
 - (xv) It was then placed in a clean plastic envelope and sealed.
 - (xvi) All monitoring information was recorded on a standard data sheet.
 - (xvii) Filters were then sent to ALS Technichem (HK) Pty Ltd. for analysis.
- (d) Maintenance and Calibration
- (i) The HVS and its accessories were maintained in good working condition, such as replacing motor brushes routinely and checking electrical wiring to ensure a continuous power supply.
 - (ii) 5-point calibration of the HVS was conducted using TE-5025A Calibration Kit prior to the commencement of baseline monitoring. Bi-monthly 5-point calibration of the HVS will be carried out during impact monitoring.
 - (iii) Calibration certificate of the HVSs are provided in Appendix E.

2.5.2 1-hour TSP Monitoring

(a) Measuring Procedures

The measuring procedures of the 1-hour dust meter were in accordance with the Manufacturer's Instruction Manual as follows:-

- (i) Turn the power on.
- (ii) Close the air collecting opening cover.
- (iii) Push the "TIME SETTING" switch to [BG].
- (iv) Push "START/STOP" switch to perform background measurement for 6 seconds.
- (v) Turn the knob at SENSI ADJ position to insert the light scattering plate.
- (vi) Leave the equipment for 1 minute upon "SPAN CHECK" is indicated in the display.
- (vii) Push "START/STOP" switch to perform automatic sensitivity adjustment. This measurement takes 1 minute.
- (viii) Pull out the knob and return it to MEASURE position.
- (ix) Push the "TIME SETTING" switch the time set in the display to 3 hours.
- (x) Lower down the air collection opening cover.
- (xi) Push "START/STOP" switch to start measurement.

(b) Maintenance and Calibration

- (i) The 1-hour TSP meter was calibrated at 1-year intervals against a continuous particulate TEOM Monitor, Series 1400ab. Calibration certificates of the Laser Dust Monitors are provided in Appendix E.
- (ii) 1-hour validation checking of the TSP meter against HVS is carried out yearly at the air quality monitoring locations.

2.6 Monitoring Schedule for the Reporting period

2.6.1 The schedule for environmental monitoring in January 2017 is provided in Appendix F.

2.7 Results and Observations

2.7.1 The monitoring results for 1-hour TSP and 24-hour TSP are summarized in Table 2.4 and 2.5 respectively. Detailed impact air quality monitoring results are presented in Appendix G.

Table 2.4 Summary of 1-hour TSP Monitoring Results in the Reporting Period

Location	Average ($\mu\text{g}/\text{m}^3$)	Range ($\mu\text{g}/\text{m}^3$)	Action Level ($\mu\text{g}/\text{m}^3$)	Limit Level ($\mu\text{g}/\text{m}^3$)
AM2 (Fanling Government Secondary School)	71.6	66.6 – 75.1	317.8	500

Table 2.5 Summary of 24-hour TSP Monitoring Results in the Reporting Period

Location	Average ($\mu\text{g}/\text{m}^3$)	Range ($\mu\text{g}/\text{m}^3$)	Action Level ($\mu\text{g}/\text{m}^3$)	Limit Level ($\mu\text{g}/\text{m}^3$)
AM2 (Fanling Government Secondary School)	68.1	54.6 – 88.4	200.7	260

2.7.2 The major dust source during the monitoring was mainly from nearby traffic emission.

2.7.3 All 1-hour and 24-hour TSP results were below the Action and Limit Level at all monitoring locations in the reporting period.

2.7.4 The event action plan is annexed in Appendix J.

2.7.5 Weather information including wind speed and wind direction is annexed in Appendix H. The information was obtained from the Hong Kong Observatory Tai Po and Tai Mei Tuk Automatic Weather Stations.

3 NOISE MONITORING

3.1 Monitoring Requirements

3.1.1 In accordance with the EM&A Manual, impact noise monitoring was conducted for at least once per week during the construction phase of the Contract. The Action and Limit level of the noise monitoring is provided in Appendix D.

3.2 Monitoring Equipment

3.2.1 Noise monitoring was performed using sound level meter at each designated monitoring station. The sound level meters deployed comply with the International Electrotechnical Commission Publications (IEC) 651:1979 (Type 1) and 804:1985 (Type 1) specifications. Acoustic calibrator was deployed to check the sound level meters at a known sound pressure level. Brand and model of the equipment is given in Table 3.1.

Table 3.1 Noise Monitoring Equipment

Equipment	Brand and Model
Integrated Sound Level Meter	B&K 2238
Acoustic Calibrator	Rion NC-73

3.3 Monitoring Locations

3.3.1 Monitoring stations M2 and M3 were set up at the proposed locations in accordance with updated EM&A Manual. Figure 1.2a-b shows the locations of the monitoring stations. Table 3.2 describes the details of the monitoring stations.

Table 3.2 Locations of Impact Noise Monitoring Stations

Monitoring Station	Location	Description
M2	West Tai Wo	1.2m from the ground floor free-field of the Residential
M3	Fanling Government Secondary School	1m from the exterior of the roof top façade of the school

3.4 Monitoring Parameters and Frequency

3.4.1 Table 3.3 summarizes the monitoring parameters, frequency and duration of impact noise monitoring.

Table 3.3 Noise Monitoring Parameters, Frequency and Duration

Parameter	Frequency
30-mins measurement at each monitoring station between 0700 and 1900 on normal weekdays. L_{eq} , L_{10} and L_{90} would be recorded.	At least once per week

3.5 Monitoring Methodology

3.5.1 Monitoring Procedure

- (a) Façade measurement was made at monitoring station M3, while free-field measurement was made at monitoring station M2.
- (b) The sound level meter was set on a tripod at a height of 1.2 m above the ground for free-field measurements at monitoring station M2.
- (c) The battery condition was checked to ensure the correct functioning of the meter.
- (d) Parameters such as frequency weighting, the time weighting and the measurement time were set as follows:-
 - (i) frequency weighting: A
 - (ii) time weighting: Fast
 - (iii) time measurement: $L_{eq(30\text{-minutes})}$ during non-restricted hours i.e. 07:00 – 1900 on normal weekdays; $L_{eq(5\text{-minutes})}$ during restricted hours i.e. 19:00 – 23:00 and 23:00 – 07:00 of normal weekdays, whole day of Sundays and Public Holidays
- (e) Prior to and after each noise measurement, the meter was calibrated using the acoustic calibrator for 94dB(A) at 1000 Hz. If the difference in the calibration level before and after measurement was more than 1 dB(A), the measurement would be considered invalid and repeat of noise measurement would be required after re-calibration or repair of the equipment.
- (f) During the monitoring period, the L_{eq} , L_{10} and L_{90} were recorded. In addition, site conditions and noise sources were recorded on a standard record sheet.
- (g) Noise measurement was paused during periods of high intrusive noise (e.g. dog barking, helicopter noise) if possible. Observations were recorded when intrusive noise was unavoidable.
- (h) Noise monitoring was cancelled in the presence of fog, rain, wind with a steady speed exceeding 5m/s, or wind with gusts exceeding 10m/s.

3.5.2 Maintenance and Calibration

- (a) The microphone head of the sound level meter was cleaned with soft cloth at regular intervals.
- (b) The meter and calibrator were sent to the supplier or HOKLAS laboratory to check and calibrate at yearly intervals.
- (c) Calibration certificates of the sound level meters and acoustic calibrators are provided in Appendix E.

3.6 Monitoring Schedule for the Reporting period

3.6.1 The schedule for environmental monitoring in January 2017 is provided in Appendix F.

3.7 Monitoring Results

3.7.1 The monitoring results for construction noise are summarized in Table 3.4 and the monitoring data is provided in Appendix I.

Table 3.4 Summary of Construction Noise Monitoring Results in the Reporting Period

Location	Average, dB(A), L_{eq} (30 mins)	Range, dB(A), L_{eq} (30 mins)	Limit Level, dB(A), L_{eq} (30 mins)
M2* (West Tai Wo)	69.0	68.1 – 70.2	75
M3# (Fanling Government Secondary School)	63.9	60.6 – 65.3	65/70

*+3dB(A) Façade correction included

Limit Level of 70dB(A) applies to education institutes while 65dB(A) applies during school examination period.

- 3.7.2 No Action or Limit Level exceedance of construction noise was recorded in the reporting month. No noise complaints related to 0700 – 1900 hours on normal weekdays was received and followed by Environmental Team in the reporting month.
- 3.7.3 Major noise sources during noise monitoring in the reporting period were mainly road traffic noise.
- 3.7.4 The event action plan is annexed in Appendix J.

4 ENVIRONMENTAL SITE INSPECTION AND AUDIT

4.1 Site Inspection

4.1.1 Site Inspections were carried out on a weekly basis to monitor the implementation of proper environmental pollution control and mitigation measures for the Contract. In the reporting period, 4 site inspections were carried out respectively on 3, 10, 19 and 24 January 2017 for the Contract. While no specific observation was recorded, recommendations on remedial actions were given to the Contractor for precautionary purpose.

4.1.2 The environmental site inspections summaries are provided in Appendix K.

4.1.3 Particular observations during the site inspections are described below:

Air Quality

4.1.4 Water sprayed on open site areas was found inadequate at SA324 and SA320. The Contractor should spray the open site areas with adequate water to prevent windblown dust emission.

4.1.5 Public access road at SA328 was observed dusty. The Contractor should provide sufficient measures to keep the public access road clear of dusty materials.

4.1.6 Exposed stockpile of dusty materials were found at SA340. The Contractor should cover the stockpile entirely by impervious sheeting.

Noise

4.1.7 No adverse observation was identified in the reporting period.

Water Quality

4.1.8 Silts and debris were found near the entrance of drainage system at NB76. The Contractor should remove the sandy materials and implement measures to prevent silts and debris from entering the drainage system.

Chemical and Waste Management

4.1.9 Construction materials and wastes were found near existing vegetation at SA320. The Contractor should remove the construction materials and wastes to keep the site clean and tidy.

4.1.10 General refuse was found scattered on ground at SA320. The Contractor should remove the general refuse and keep the site clean and tidy.

4.1.11 Chemical container without drip tray was found at SA320. The Contractor should provide secondary containment to avoid potential leakage.

4.1.12 Construction wastes and materials were found scattered on ground at SA325 and SA326. The Contractor should remove the construction wastes and materials to keep the site clean and tidy.

Landscape and Visual Impact

4.1.13 No adverse observation was identified in the reporting period.

Miscellaneous

4.1.14 Stagnant water was found at SA340. The Contractor should remove the water or apply larvicidal oil to prevent mosquito breeding.

4.2 Advice on the Solid and Liquid Waste Management Status

- 4.2.1 The Contractor has registered as chemical waste producers for the Contract. C&D material sorting was carried out on site. Sufficient numbers of receptacles were available for general refuse collection.
- 4.2.2 As advised by the Contractor, 1,650 m³ of inert C&D material was generated in the reporting month (360 m³ disposed of as public fill to Tuen Mun 38, 438 m³ of inert C&D materials was reused on site, 517 m³ of inert C&D materials was reused in other projects and 335 m³ was broken concrete). For C&D wastes, 115 m³ of general refuse was disposed of at NENT landfill, 72 kg of paper/cardboard packaging, 845 kg of plastics and 0 kg of metals were collected by recycling Contractors, and 0 kg of chemical wastes was collected by licensed Contractors in the reporting period.
- 4.2.3 The actual amounts of different types of waste generated by the activities of the Project in the reporting period are shown in Table 4.1.

Table 4.1 Summary of Waste Flow Table

Waste Type	Actual Amount	Disposal/Reuse Locations
Inert C&D materials disposed as public fill	360 m ³	Tuen Mun 38
Broken concrete	335 m ³	Tuen Mun 38
C&D wastes disposed as general refuse	115 m ³	NENT Landfill
Paper/cardboard packaging	72 kg	Recycling Facilities
Plastics	845 kg	Recycling Facilities
Metals	0 kg	Recycling Facilities
C&D materials reused on site	438 m ³	Site Area
C&D materials reused in other projects	517 m ³	Other projects
Chemical wastes	0 kg	Licensed Contractors

- 4.2.4 The Contractor was advised to maintain on-site waste sorting and recording system and maximize reuse / recycle of C&D wastes.

4.3 Environmental Licenses and Permits

- 4.3.1 The environmental licenses and permits for Stage 2 of the Project and valid in the reporting period is summarized in Table 4.2.

Table 4.2 Summary of Environmental Licensing and Permit Status

Statutory Reference	License/ Permit	License or Permit No.	Valid Period		License / Permit Holder	Remarks
			From	To		
EIAO	Environmental Permit	EP-324/2008/D	27/08/2015	N/A	HyD	
WPCO	Discharge License (Site)	WT00017159-2013	18/09/2013	30/09/2018	CSHK	--
WDO	Chemical Waste Producer Registration	5213-722-C3822-01	05/09/2013	N/A	CSHK	Chemical waste produced in Contract HY/2012/06

Statutory Reference	License/ Permit	License or Permit No.	Valid Period		License / Permit Holder	Remarks
			From	To		
WDO	Billing Account for Disposal of Construction Waste	7017860	N/A	N/A	CSHK	Waste disposal in Contract HY/2012/06
NCO	Construction Noise Permit	GW-RN0777-16	26/10/2016	02/04/2017	CSHK	Zone 2 Dismantling of steel platform of Kau Lung Hang Vehicular Bridge
		GW-RN0884-16	06/12/2016	28/02/2017	CSHK	Zone 2 Removal of Catch Fence near Ho Ka Yuen
		GW-RN0888-16	06/12/2016	10/02/2017	CSHK	Zone 2 Roofing Installation for KLHVB
		GW-RN0914-16	20/12/2016	31/05/2017	CSHK	Zone 2 Demolition of NWPFB near Ho Ka Yuen
		GW-RN0938-16	15/12/2016	14/06/2017	CSHK	Zone 4 Grouting for Piling Works near Wo Hop Shek Village
		GW-RN0958-16	01/01/2017	05/03/2017	CSHK	Zone 2 Removal of Steel Platform at NB of Fanling Highway near KLHVB
		GW-RN0031-17	17/01/2017	25/03/2017	CSHK	Zone 4 Preparation works for demolition of WHSB
		GW-RN0039-17	19/01/2017	26/03/2017	CSHK	Zone 4 Demolition of WHSB

4.4 Implementation Status of Environmental Mitigation Measures

4.4.1 A summary of the Implementation Schedule of Environmental Mitigation Measures (EMIS) is presented in Appendix C.

4.5 Summary of Exceedances of the Environmental Quality Performance Limit

- 4.5.1 All 1-hour and 24-hour TSP monitoring results complied with the Action / Limit Levels in the reporting period.
- 4.5.2 No Action or Limit Level exceedance of construction noise was recorded in the reporting month. No noise complaints related to 0700 – 1900 hours on normal weekdays was received and followed by Environmental Team in the reporting month.

4.6 Summary of Complaints, Notification of Summons and Successful Prosecutions

- 4.6.1 The Environmental Complaint Handling Procedure is annexed in Figure 4.1.
- 4.6.2 One (1) air-related complaint was received on 13 January 2017 and followed up by the Environmental Team in the reporting month. The details of the complaint are described in Section 4.6.4 and the full complaint investigation report is annexed in Appendix M.
- 4.6.3 No notification of summons and successful prosecution was received in the reporting period.
- 4.6.4 A complaint was received by the 1823 enquiry and complaint hotline on 5 January 2017. The complaint was referred to the Environmental Team by the Contractor on 13 January 2017.
- 4.6.5 A complainant complained against the dust emission generated by the Widening of Fanling Highway construction site on Tai Wo Service Road West near Tai Hang Village.
- 4.6.6 The complainant also complained that Highway Department did not conduct road surface cleansing, which affects residents' health. He/she requires the Highway Department to follow up.
- 4.6.7 Statistics on complaints, notifications of summons and successful prosecutions are summarized in Appendix L.

5 FUTURE KEY ISSUES

5.1 Construction Programme for the Coming Months

5.1.1 The major construction works for the Contract in February 2017 will be:-

- Site clearance
- Ground investigation
- Pipe laying
- Retaining wall construction
- Noise Barrier
- Excavation
- Backfilling
- Drainage
- Temporary bridge construction
- House Construction
- Foot Bridge demolition
- Bridge construction
- Piling

5.2 Key Issues for the Coming Month

5.2.1 Key issues to be considered in February 2017:-

- Properly store and label oils and chemicals on site;
- Chemical, chemical waste and waste management;
- Collection of construction waste should be carried out regularly;
- Properly maintain all drainage facilities and wheel washing facilities on site;
- Exposed slopes should be covered up properly if no temporary work will be conducted;
- Quieter powered mechanical equipment should be used;
- Suppress dust generated from excavation activities and haul road traffic; and
- Tree protective measures for all retained trees should be well maintained.

5.3 Monitoring Schedule for the Coming Month

5.3.1 The tentative schedule for environmental monitoring in February 2017 is provided in Appendix F.

6 CONCLUSIONS AND RECOMMENDATIONS

6.1 Conclusions

- 6.1.1 The construction phase and EM&A programme of the Contract commenced on 21 November 2013.
- 6.1.2 All 1-hour and 24-hour TSP monitoring results complied with the Action / Limit Levels in the reporting period.
- 6.1.3 No Action or Limit Level exceedance of construction noise was recorded in the reporting month. No noise complaints related to 0700 – 1900 hours on normal weekdays was received and followed by Environmental Team in the reporting month.
- 6.1.4 4 environmental site inspections were carried out in January 2017. Recommendations on remedial actions were given to the Contractors for the deficiencies identified during the site audits.
- 6.1.5 One (1) air-related complaint was received on 13 January 2017 and followed up by the Environmental Team in the reporting month. The details of the complaint are described in Section 4.6.4 and the full complaint investigation report is annexed in Appendix M.
- 6.1.6 No notification of summons and successful prosecution was received in the reporting period.

6.2 Recommendations

- 6.2.1 According to the environmental site inspections performed in the reporting period, the following recommendations on remedial actions were provided to the Contractor for precautionary purpose:

Air Quality Impact

- The Contractor should spray the open site areas with adequate water to prevent windblown dust emission.
- The Contractor should provide sufficient measures to keep the public access road clear of dusty materials.
- The Contractor should cover the stockpile entirely by impervious sheeting.

Noise Impact

- No adverse observation was identified in the reporting period.

Water Quality Impact

- The Contractor should remove the sandy materials and implement measures to prevent silts and debris from entering the drainage system.

Chemical and Waste Management

- The Contractor should remove the construction materials and wastes to keep the site clean and tidy.
- The Contractor should remove the general refuse and keep the site clean and tidy.
- The Contractor should provide secondary containment to avoid potential leakage.
- The Contractor should remove the construction wastes and materials to keep the site clean and tidy.

Landscape and Visual Impact.

- No adverse observation was identified in the reporting period.

Miscellaneous

- The Contractor should remove the stagnant water or apply larvicidal oil to prevent mosquito breeding.

FIGURES

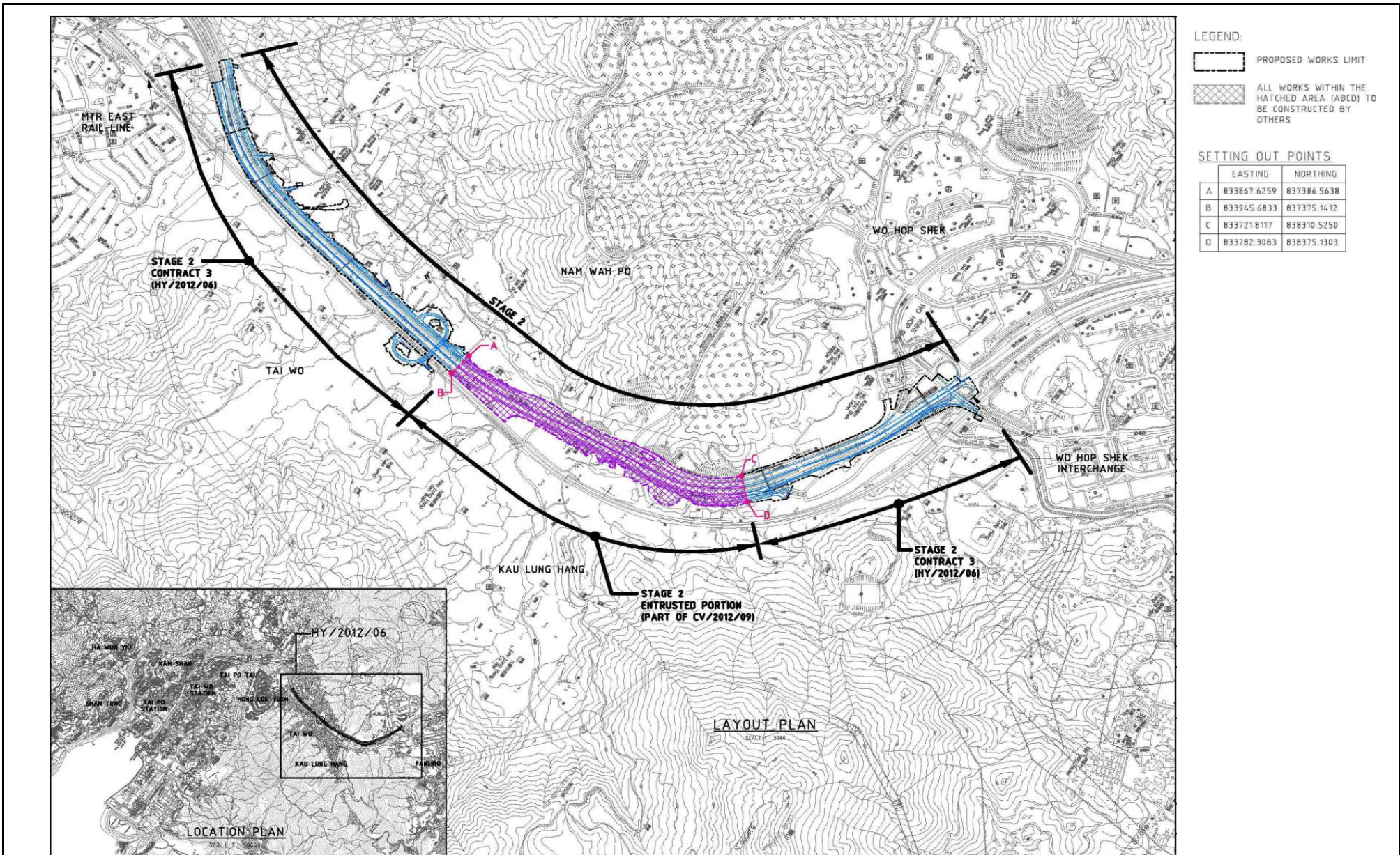

This Drawing has been prepared for the use of AECOM's client. It may not be used, modified, reproduced or relied upon by third parties, except as agreed by AECOM or as required by law. AECOM accepts no responsibility, and denies any liability whatsoever, to any party that uses or relies on this drawing without AECOM's express written consent.

CONTRACT NO. HY/2012/06
 WIDENING OF FANLING HIGHWAY
 - TAI HANG TO WO HOP SHEK INTERCHANGE



Layout Plan

Date: Dec 2013

Figure 1.1

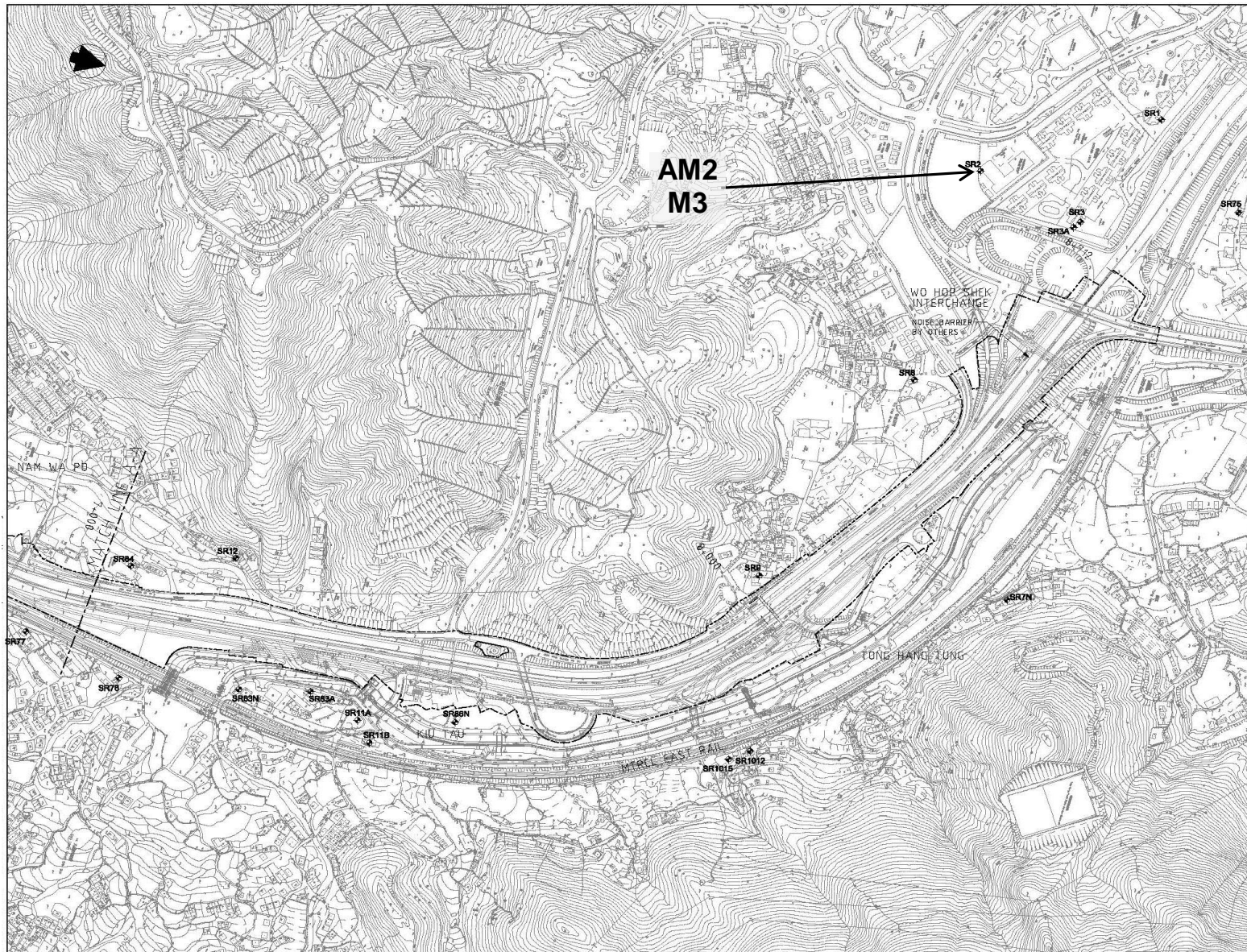

This Drawing has been prepared for the use of AECOM's client. It may not be used, modified, reproduced or relied upon by third parties, except as agreed by AECOM or as required by law. AECOM accepts no responsibility, and denies any liability whatsoever, to any party that uses or relies on this drawing without AECOM's express written consent.

CONTRACT NO. HY/2012/06
 WIDENING OF FANLING HIGHWAY
 - TAI HANG TO WO HOP SHEK INTERCHANGE



Locations of Monitoring Station

Date: Dec 2013

Figure 1.2a

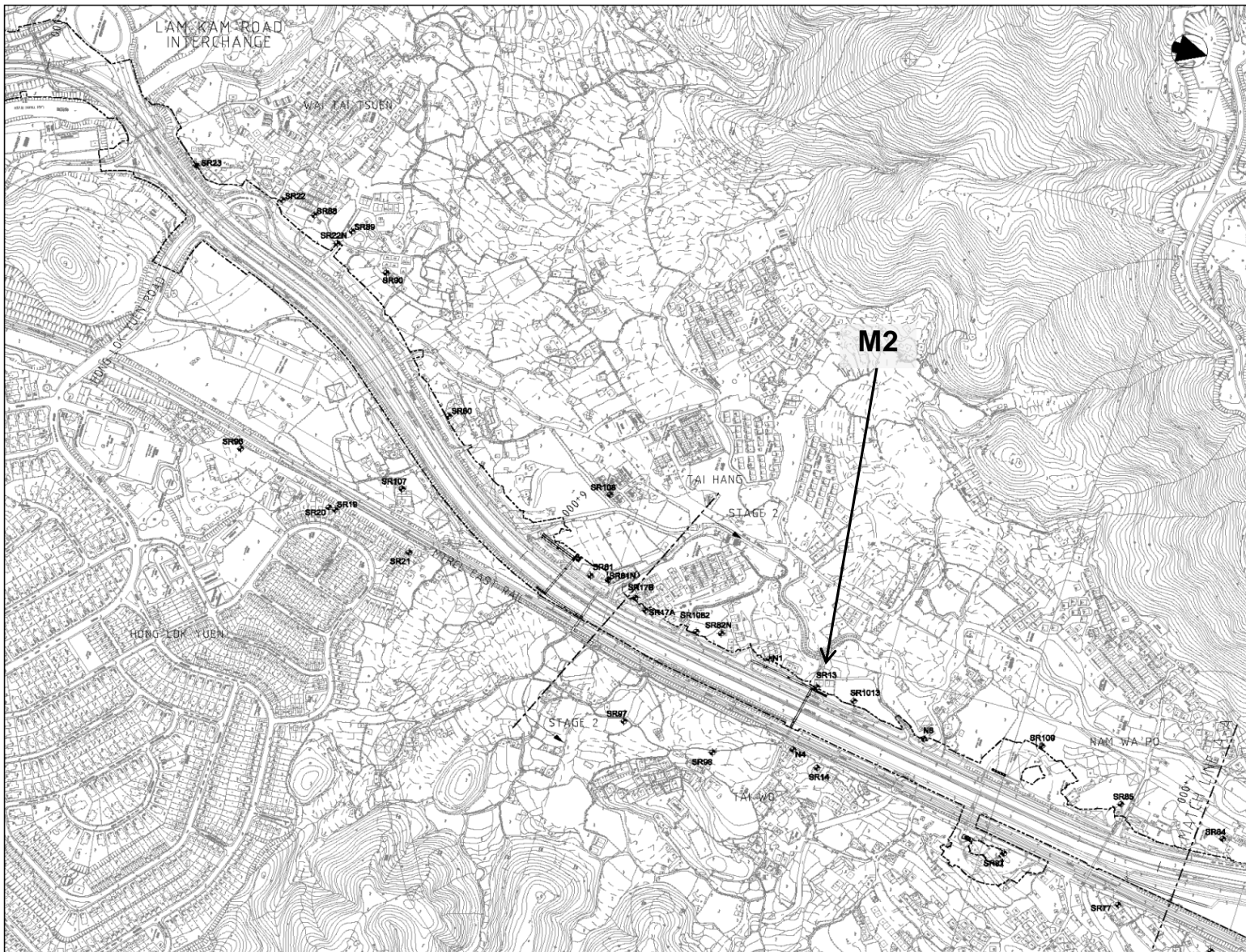

This Drawing has been prepared for the use of AECOM's client. It may not be used, modified, reproduced or relied upon by third parties, except as agreed by AECOM or as required by law. AECOM accepts no responsibility, and denies any liability whatsoever, to any party that uses or relies on this drawing without AECOM's express written consent.

CONTRACT NO. HY/2012/06
 WIDENING OF FANLING HIGHWAY
 - TAI HANG TO WO HOP SHEK INTERCHANGE



Locations of Monitoring Station

Date: Dec 2013

Figure 1.2b

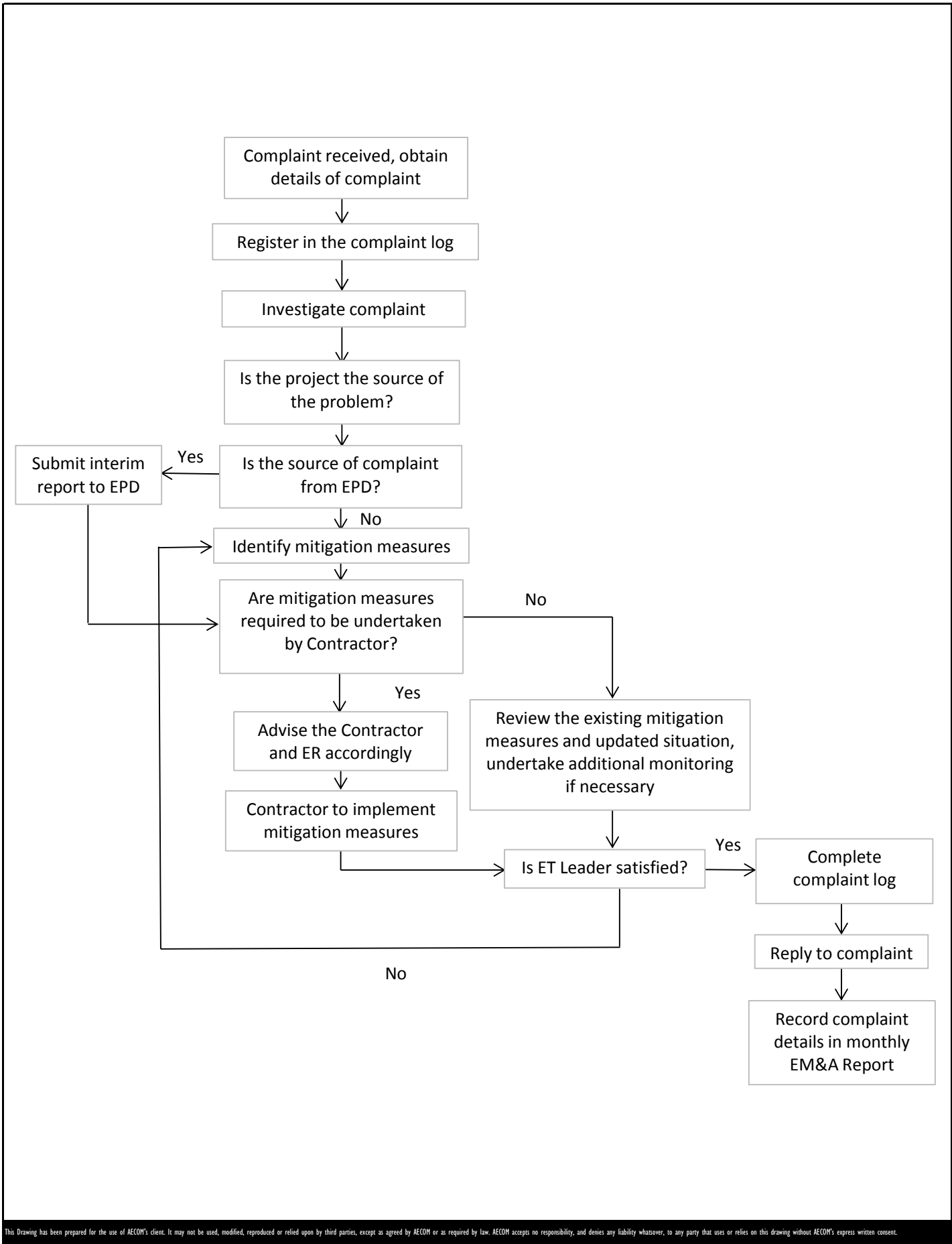

This Drawing has been prepared for the use of AECOM's client. It may not be used, modified, reproduced or relied upon by third parties, except as agreed by AECOM or as required by law. AECOM accepts no responsibility, and denies any liability whatsoever, to any party that uses or relies on this drawing without AECOM's express written consent.

CONTRACT NO. HY/2012/06
 WIDENING OF FANLING HIGHWAY
 - TAI HANG TO WO HOP SHEK INTERCHANGE



Environmental Complaint Handling Procedure

**APPENDIX A
PROJECT ORGANIZATION STRUCTURE**

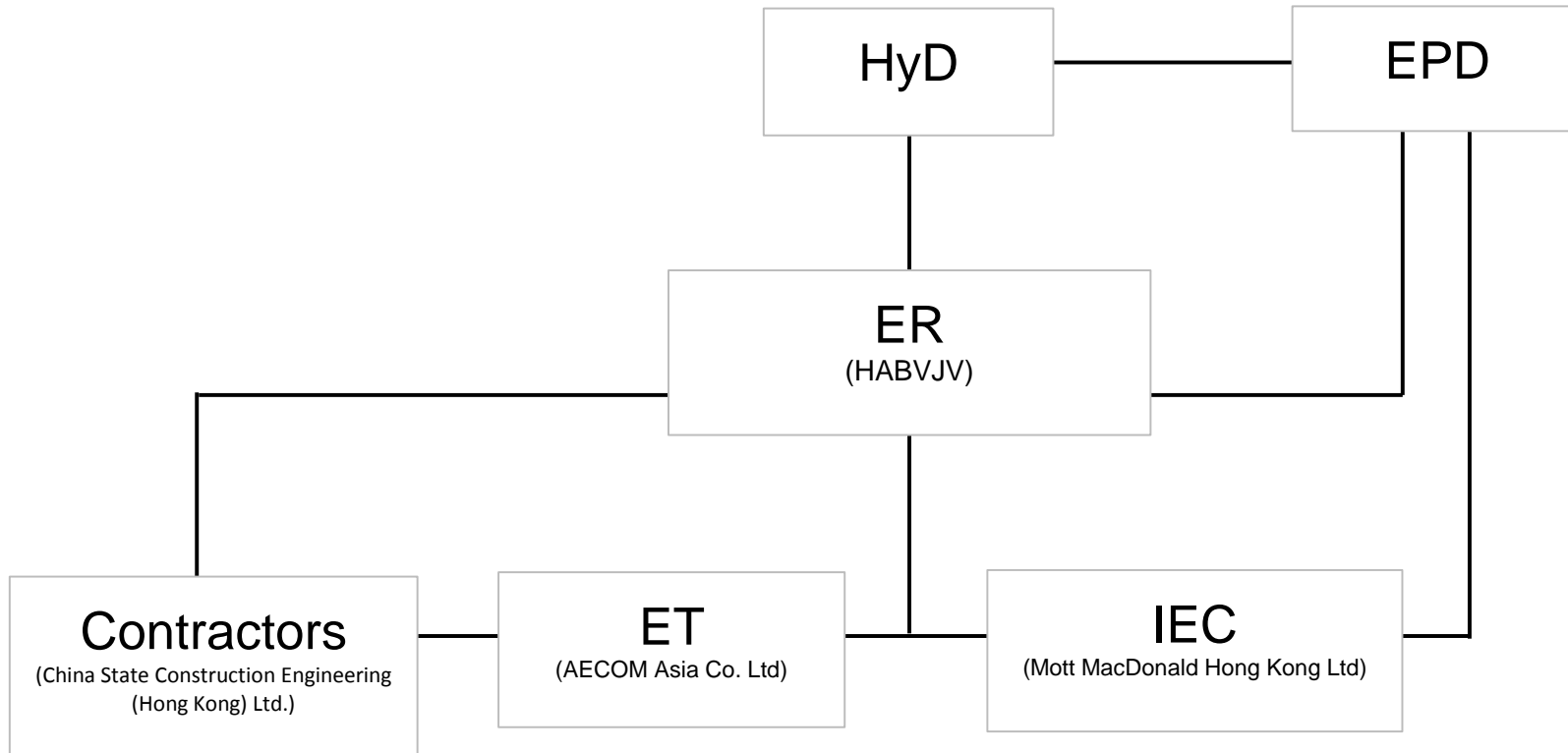

This Drawing has been prepared for the use of AECOM's client. It may not be used, modified, reproduced or relied upon by third parties, except as agreed by AECOM or as required by law. AECOM accepts no responsibility, and denies any liability whatsoever, to any party that uses or relies on this drawing without AECOM's express written consent.

CONTRACT NO. HY/2012/06
 WIDENING OF FANLING HIGHWAY
 - TAI HANG TO WO HOP SHEK INTERCHANGE



Project Organization Structure

**APPENDIX B
CONSTRUCTION PROGRAMMES**

Activity ID	Activity Name	Dur. % Complete	Rem. Duration	Original Duration	Start	Finish	Total Float	2016				2017				
								Dec	Jan	Feb	Mar	Dec	Jan	Feb	Mar	
Contract Condition																
General																
Contract Condition																
KD20	KD-20 (1064d)- Stage 1: Achievement: Whole length of	0%	0	0		31-Dec-16	3									31-Dec-16* ◆ KD-20 (1064d)- Stage 1: Achievement: Whole length of Southern Trunk
POSSA323A	Site Area SA323A (360d) (not required)	0%	0	0	20-Dec-16		1297									◆ Site Area SA323A (360d) (not required)
POSSA327	Site Area SA327 (180d)	0%	0	0	20-Dec-16*		-719									◆ Site Area SA327 (180d)
POSSA327A	Site Area SA327A (730d)	0%	0	0	20-Dec-16*		-521									◆ Site Area SA327A (730d)
POSSA345	Site Area SA345 (0d)	0%	0	0	20-Dec-16*		-386									◆ Site Area SA345 (0d)
ZONE 1 (Ch. 5640 to 5880)																
Noise Barrier Along TWSR-West and Laying New Utilities																
DSD Southern Trunk Sewer, Water Main, Fire Main Works																
DSD Southern Trunk Sewer, Water Main Fire Main Works																
DSD0110	DSD Trunk Sewer Laying - overall inspection	58.33%	5	12	05-Dec-16 A	24-Dec-16	5									
DSD0120	DSD Trunk Sewer Laying - overall rectification	25%	9	12	17-Dec-16 A	31-Dec-16	1									
NB42 (Ch.5640-5740)-TWSR West Side																
DSD Southern Trunk Sewer, Water Main Fire Main Works																
TSZ10140	Firemain installation (along NB42)	66.22%	25	74	20-Aug-16 A	20-Jan-17	28									
Noise Barrier Along Fanling Highway N/B																
Site Clearance & Demolition of Existing Structure																
Underground Utility Works																
ADVZ20175	All UU and backfill along TWSR-W complete	0%	0	0		20-Dec-16	22									20-Dec-16 ◆ All UU and backfill along TWSR-W complete
ADVZ20180	Utility cable changeover period (NWT)	0%	184	184	20-Dec-16	21-Jun-17	209									
ADVZ20182	Additional Utility cable changeover period (PCCW, HCG)	0%	273	273	20-Dec-16	18-Sep-17	120									
TWSR-West Construction																
Drainage & Road Works																
Ch 5640-5880																
RDZ10090	Z1: New Tai Wo Service Road West - Drainage & Road works (2 lanes)	54.12%	78	170	15-Aug-16 A	31-Mar-17	0									
ZONE 2 (Ch. 5880 to 6930)																
General																
DRM Proposal																
DRM Proposal																
ADVZ20200	Utility cable changeover period (All Utility Companies)(9 months)	17.95%	224	273	20-Oct-16 A	31-Jul-17*	0									
ADVZ20220	New TWSR-W construction period	57.61%	78	184	15-Aug-16 A	31-Mar-17	0									
Noise Barrier Along TWSR-West and Laying New Utilities																
NB48 (Ch.5995-6120)-TWSR West Side																
Noise Barrier Works																
NB00390	NB48 (Ch5995-6060) - backfilling	66.67%	6	18	05-Oct-16 A	28-Dec-16	60									
DSD Southern Trunk Sewer, Water Main Fire Main Works																
TSZ10440	Firemain installation (along NB48, 0-60m)	88.46%	18	156	20-Jun-16 A	12-Jan-17	0									
TSZ10490	Firemain installation (along NB48, 60-110m)	88.46%	18	156	20-Jun-16 A	12-Jan-17	0									
NB54 (Ch.6240-6280)-TWSR West Side																
Noise Barrier Works																
NB00720	NB54 - NB post & panel installation	0%	5	5	20-Dec-16	24-Dec-16	689									
DSD Southern Trunk Sewer, Water Main Fire Main Works																
TSZ10630	Watermain installation (along NB54)	85.4%	20	137	20-May-16 A	14-Jan-17	1027									
TSZ10640	Firemain installation (along NB54)	0%	30	30	19-Dec-16 A	26-Jan-17	76									
NB54A (Ch.6290-6350)-TWSR West Side																
Noise Barrier Works																
NB00770	NB54A - backfilling	0%	12	12	20-Dec-16	05-Jan-17	79									
NB00790	NB54A - NB post & panel installation	0%	5	5	06-Jan-17	11-Jan-17	677									
DSD Southern Trunk Sewer, Water Main Fire Main Works																
TSZ10680	Watermain installation (along NB54A)	91.15%	20	226	14-Mar-16 A	14-Jan-17	1027									
TSZ10690	Firemain installation (along NB54A)	0%	31	25	19-Dec-16 A	27-Jan-17	17									
NB57 (Ch.6365-6445)-TWSR West Side																
DSD Southern Trunk Sewer, Water Main Fire Main Works																
TSZ10730	Watermain installation (along NB57)	0%	37	27	12-Dec-16 A	11-Feb-17	1									
TSZ10740	Firemain installation (along NB57)	0%	30	30	17-Jan-17	28-Feb-17	1									
TSZ10990	Backfilling for UU and Firemain & Watermain	0%	12	12	01-Mar-17	14-Mar-17	1									
NB58 (Ch.6445-6480)-TWSR West Side																
Noise Barrier Works																
NB00930	NB58 - NB post & panel installation	54.17%	22	48	20-Sep-16 A	17-Jan-17	672									
DSD Southern Trunk Sewer, Water Main Fire Main Works																
TSZ10790	Firemain installation (along NB58)	82.35%	9	51	29-Aug-16 A	31-Dec-16	1038									
NB59 (Ch.6490-6590)-TWSR West Side																
Noise Barrier Works																
NB01000	NB59 - NB post installation	25%	12	16	15-Oct-16 A	05-Jan-17	682									
DSD Southern Trunk Sewer, Water Main Fire Main Works																
TSZ10840	Firemain installation (along NB59)	94.38%	9	160	20-May-16 A	31-Dec-16	24									
NB63 (Ch.6610-6700)-TWSR West Side																
DSD Southern Trunk Sewer, Water Main Fire Main Works																

	Project ID: WP Rev 04 (1612)	Contract No. HY/2012/06 Widening of Fanling Highway - Tai Hang to Wo Hop Shek Interchange 3 Month Rolling Program(20-Dec-16)		Date	Revision	C...	A..
	Layout: 3 Month Rolling Program			13-May-14	WP Rev 1		
Page 1 of 6				30-Jun-14	WP Rev 1A		
				28-Aug-15	WP Rev 2		
				07-Apr-16	WP Rev 3		
				08-Nov-16	WP Rev 4		

Activity ID	Activity Name	Dur. % Complete	Rem. Duration	Original Duration	Start	Finish	Total Float	2016				2017			
								Dec	Jan	Feb	Mar	Jan	Feb	Mar	
NB03240	Excavation & DN600 pipe laying	0%	75	75	09-Jan-17	18-Apr-17	455								
NB51 (Ch.5935-6055)-FH S/B Side															
Noise Barrier Works															
NB02280	NB51 ID1-3 (0-25m) - Footing & Wall Structure	0%	90	90	20-Dec-16	19-Apr-17	549								
NB02320	NB51(25-118m) - Sheet piling & Excavation	0%	18	18	29-Oct-16 A	12-Jan-17	400								
NB02330	NB51(25-118m) - Footing & Wall Structure	0%	90	90	13-Jan-17	12-May-17	400								
NB52 (Ch.6055-6125) -FH S/B Side (MTRC I&P Area)															
Noise Barrier Works															
NB02370	NB52 - Sheet piling & Excavation	0%	26	26	04-Nov-16 A	21-Jan-17	613								
NB02380	NB52 - Footing & Wall Structure	0%	50	50	18-Nov-16 A	27-Feb-17	589								
NB02390	NB52- backfilling	0%	50	50	28-Feb-17	02-May-17	589								
NB02400	NB52 - NB production	0%	45	45	28-Feb-17	13-Apr-17	742								
NB53 (Ch.6125-6300) -FH S/B Side (MTRC I&P Area)															
Noise Barrier Works															
NB02430	Precautionary Measure installation	0%	26	26	20-Dec-16	21-Jan-17	495								
NB02440	NB53 (0-100m) - Sheet piling & Excavation	0%	26	26	23-Jan-17	01-Mar-17	542								
NB02450	NB53 (0-100m) - Footing & Wall Structure	0%	60	60	02-Mar-17	17-May-17	542								
NB02490	NB53 ID2-3 (100-125m), 18nos Predrilling	0%	10	10	13-Feb-17	23-Feb-17	484								
NB02500	NB53 ID2-3 (100-125m) 18nos Piling- 1 rigs	0%	27	27	24-Feb-17	27-Mar-17	484								
NB02590	NB53 (125-180m) - NB production	91.62%	14	167	20-May-16 A	02-Jan-17	843								
NB02600	NB53 (125-180m) - NB post & panel installation	0%	5	5	03-Jan-17	07-Jan-17	680								
NB55 (Ch.6300-6360)-FH S/B Side (MTRC I&P Area)															
Noise Barrier Works															
NB02640	NB55 - Footing & Wall Structure	95.95%	24	593	07-Nov-14 A	19-Jan-17	484								
NB02650	NB55- backfilling	0%	50	50	20-Jan-17	27-Mar-17	484								
NB02660	NB55 - NB production	87.46%	40	319	15-Jan-16 A	28-Jan-17	817								
NB56 (Ch.6360-6400)-FH S/B Side (MTRC I&P Area)															
Noise Barrier Works															
NB02730	NB56 - NB production	94.55%	14	257	20-Feb-16 A	02-Jan-17	843								
NB02740	NB56 - NB post & panel installation	0%	5	5	03-Jan-17	07-Jan-17	680								
NB61 (Ch.6400-6560)-FH S/B Side (MTRC I&P Area)															
Noise Barrier Works															
NB02770	NB61 (0-50m) - Sheet piling & Excavation	0%	18	18	20-Dec-16	12-Jan-17	576								
NB02780	NB61 (0-50m) - Footing & Wall Structure	0%	50	50	13-Jan-17	20-Mar-17	576								
NB02850	NB61 (50-160m) - NB production	0%	45	45	20-Dec-16	02-Feb-17	812								
NB02860	NB61 (50-160m) - NB post & panel installation	0%	5	5	06-Feb-17	10-Feb-17	658								
NB61A (Ch.6560-6745)-FH S/B Side (MTRC I&P Area)															
Noise Barrier Works															
NB02920	NB61A(0-50m) - NB production	84.38%	45	288	20-Feb-16 A	02-Feb-17	812								
NB02930	NB61A (0-50m) - NB post & panel installation	0%	5	5	06-Feb-17	10-Feb-17	658								
NB02970	NB61A ID2-3 (50-75m) - Footing & Wall Structure	88.87%	57	512	01-Apr-15 A	07-Mar-17	597								
NB02980	NB61A ID2-3 (50-75m)- backfilling	0%	20	20	08-Mar-17	30-Mar-17	612								
NB02990	NB61A ID2-3 (50-75m) - NB production	0%	45	45	08-Mar-17	21-Apr-17	734								
NB03040	NB61A (75-190m) - NB production	94.19%	15	258	20-Feb-16 A	03-Jan-17	842								
NB03050	NB61A (75-190m) - NB post & panel installation	0%	5	5	04-Jan-17	09-Jan-17	679								
Box Culvert ID3 Works															
VO58 Extension of ID3															
ID30095	Preparation work	83.33%	5	30	20-Oct-16 A	24-Dec-16	342								
ID30100	Demolish existing wing walls (N&S)	0%	30	30	28-Dec-16	09-Feb-17	195								
ID30110	Rock fill to the box culvert level	0%	20	20	10-Feb-17	04-Mar-17	195								
ID30120	Box culvert extension structure & Wing Walls	0%	90	90	06-Mar-17	19-Dec-17	195								
Other Works															
Site Clearance & Demolition of Existing Structure															
Contract Condition															
MCLT1090	New MCLT - finishes works	58.92%	99	241	20-May-16 A	29-Apr-17	595								
TCSS Works															
G54															
TCSS1500	Slow lane footing - G54 (NB61)	0%	0	0		20-Dec-16	664								
South Buffer Zone 1 (SBZ1) (within Zone 2)(Ch.6740 to 6930)															
Noise Barrier Along TWSR-West and Laying New Utilities															
NB63A (Ch.6710-6840)-TWSR West Side															
Noise Barrier Works															
NB01200	NB63A-3 - NB post installation	9.68%	28	31	17-Sep-16 A	24-Jan-17	666								
DSD Southern Trunk Sewer, Water Main Fire Main Works															
TSZ10880	Watermain installation (along NB63A)	33.33%	20	30	02-Nov-16 A	14-Jan-17	12								
TSZ10890	Firemain installation (along NB63A)	0%	30	30	29-Dec-16	10-Feb-17	12								
NB64 & NB64A (Ch.6860-6920)-TWSR West Side															
Noise Barrier Works															
NB001040	NB64 & NB64A -backfilling	0%	12	12	27-Jan-17	17-Feb-17	64								
NB001060	NB64 & NB64A -NB post & panel installation	85.17%	31	209	14-Mar-16 A	27-Jan-17	663								
DSD Southern Trunk Sewer, Water Main Fire Main Works															
TSZ10930	Watermain installation (along NB64)	53.33%	14	30	08-Dec-16 A	07-Jan-17	130								
TSZ10940	Firemain installation (along NB64)	0%	30	30	20-Dec-16	26-Jan-17	64								
TSZ11028	Demolish existing pile caps at Watermain	50%	15	30	02-Dec-16 A	09-Jan-17	1032								

20-Dec-16 ◆ Slow lane footing - G54 (NB61)

Activity ID	Activity Name	Dur. % Complete	Rem. Duration	Original Duration	Start	Finish	Total Float	2016				2017			
								Dec		Jan		Feb		Mar	
Bridge Construction															
Kau Lung Hang Vehicular Bridge															
KLH Bridge - West Ramp															
KLH.1290	West Ramp - Planting	0%	21	21	20-Dec-16	16-Jan-17	673								
KLH Bridge - Deck 1															
KLH.3430	Deck 1 - Planting	0%	21	21	20-Dec-16	16-Jan-17	673								
KLH.3630	Pedestrian walkway Roof P2 to P3	63.16%	14	38	09-Dec-16 A	07-Jan-17	5								
KLH.3640	Pedestrian walkway floor finishes P2 to P3	0%	14	14	09-Jan-17	24-Jan-17	5								
KLH Bridge - Deck 2															
KLH.3160	Pedestrian walkway Roof P5-P6	0%	14	14	09-Dec-16 A	07-Jan-17	9								
KLH.3170	Pedestrian walkway floor finishes P5-P6 (include barrier and lighting)	0%	14	14	04-Jan-17	19-Jan-17	9								
KLH.3260	Pedestrian walkway Roof P4 to P5	0%	9	9	09-Dec-16 A	31-Dec-16	10								
KLH.3270	Pedestrian walkway floor finishes P4 to P5 (include barrier and lighting)	0%	14	14	03-Jan-17	18-Jan-17	10								
KLH.3360	Pedestrian walkway Roof P3 to P4	0%	6	6	09-Dec-16 A	28-Dec-16	13								
KLH.3370	Pedestrian walkway floor finishes P3 to P4 (include barrier and lighting)	0%	14	14	29-Dec-16	14-Jan-17	13								
KLH Bridge - Deck 3															
KLH.3500	Deck 3 - Planting	0%	21	21	20-Dec-16	16-Jan-17	705								
KLH.3650	Pedestrian walkway Roof P6 to P7	24%	19	25	01-Dec-16 A	13-Jan-17	0								
KLH.3660	Pedestrian walkway floor finishes P6 to P7 (include barrier and lighting)	0%	14	14	14-Jan-17	07-Feb-17	0								
KLH Bridge - East Ramp															
KLH.3590	East Ramp - Planting	0%	34	34	20-Dec-16	08-Feb-17	1013								
KLH Bridge - Ramp R1															
Z2.KLH.1685	Ramp R1 - Ramp construction (R1P1 to P1P3)	76.67%	7	30	19-Nov-16 A	29-Dec-16	0								
Z2.KLH.1740	Ramp R1 complete	0%	0	0		06-Feb-17	0							06-Feb-17 ♦ Ramp R1 complete	
Z2.KLH.3610	Ramp R1 - Steel roof	0%	20	20	30-Dec-16	23-Jan-17	0								
Z2.KLH.3620	Ramp R1 - finishes work (include barrier and lighting)	0%	20	20	06-Jan-17	06-Feb-17	0								
KLH Bridge - Ramp R2															
Z2.KLH.1523	VO 028 - Boundary Wall to Hse 190B structure	0%	24	24	20-Dec-16*	19-Jan-17	644								
Z2.KLH.1524	VO 028 - Boundary Wall to Hse 190B E&M, Drainage	0%	26	26	20-Jan-17	27-Feb-17	644								
Z2.KLH.1530	Ramp R2 - Pile cap, abutment and pier construction	97.01%	9	301	20-Nov-15 A	31-Dec-16	2								
Z2.KLH.1540	Ramp R2 - Ramp construction	55.56%	20	45	17-Nov-16 A	14-Jan-17	0								
Z2.KLH.1545	Ramp R2 - Ramp construction (section after VBP6-7 deck)	42.86%	20	35	17-Nov-16 A	14-Jan-17	0								
Z2.KLH.1550	Ramp R2 - Steel roof	0%	24	24	13-Mar-17	10-Apr-17	-53								
Z2.KLH.1920	Ramp R2 - finishes work (include barrier and lighting)	0%	12	12	16-Jan-17	06-Feb-17	0								
Z2.KLH.2000	Prepare Shop drawing re-submission	44.44%	25	45	08-Dec-16 A	20-Jan-17	-53								
Z2.KLH.2010	Shop drawing approval	0%	2	2	21-Jan-17	23-Jan-17	-53								
Z2.KLH.2050	Factory fabrication	0%	34	34	24-Jan-17	11-Mar-17	-53								
Bridge Road Work															
Z2.KLH.2040	Landscape work of KLHVB	0%	120	120	20-Dec-16	26-May-17	574								
Lift at TWSR-W Side															
L01040	Temp work & Pile cap	0%	45	45	07-Feb-17	30-Mar-17	422								
L01094	Lift submission & ordering period	31.63%	201	294	01-Aug-16 A	31-Aug-17	404								
L01140	CLP Power available (by CLP)	55.83%	182	412	04-Apr-16 A	19-Jun-17	655								
Lift at FLHY S/B															
L01180	Earliest date for lift construction resume	0%	0	0	20-Dec-16		409							♦ Earliest date for lift construction resume	
L01190	Set up & Pile test	0%	30	30	20-Dec-16	26-Jan-17	409								
L01200	Temp work & Pier cap	0%	45	45	27-Jan-17	28-Mar-17	409								
L01300	CLP Power available (by CLP)	51.69%	214	443	04-Apr-16 A	21-Jul-17	629								
Demolition of Existing Nam Wa Po Footbridge															
Demolition Work															
Z2.NWP.1060	Temporary support installation at existing Fanling Highway	0%	45	45	17-Feb-17	11-Apr-17	-53								
Z2.NWP.1100	RMO additional road closure stopping period	0%	32	32	13-Jan-17*	13-Feb-17	0								
TWSR-West Construction															
Drainage & Road Works															
General															
CW01	1st interface connection to CW at S/B	0%	0	0		31-Jan-17*	0							31-Jan-17* ♦ 1st interface connection to CW at S/B	
Noise Barrier Along Fanling Highway S/B															
NB62 (Ch.6745-6910)-FH S/B Side (MTRC I&P Area)															
Noise Barrier Works															
NB03090	NB62 (0-80m) - Footing & Wall Structure	11.67%	53	60	12-Dec-16 A	02-Mar-17	601								
NB03100	NB62 (0-80m) - backfilling	0%	20	20	03-Mar-17	25-Mar-17	616								
NB03110	NB62 (0-80m) - NB production	0%	45	45	03-Mar-17	16-Apr-17	739								
NB03130	NB62 (80-110m) Under bridge - Sheet piling & Excavation	0%	12	12	03-Jan-17*	16-Jan-17	555								
NB03140	NB62 (80-110m) Under bridge - Footing & Wall Structure	0%	25	25	17-Jan-17	22-Feb-17	608								
NB03150	NB62 (80-110m) Under bridge - backfilling	0%	14	14	23-Feb-17	10-Mar-17	629								
NB03160	NB62 (80-110m) Under bridge - NB production	0%	45	45	23-Feb-17	08-Apr-17	747								
NB03180	NB62 (110-170m) - Sheet piling & Excavation	0%	18	18	17-Jan-17	14-Feb-17	555								
NB03190	NB62 (110-170m) - Footing & Wall Structure	0%	60	60	15-Feb-17	29-Apr-17	555								
NB70 (Ch.6910-6930)-FH S/B Side															
Noise Barrier Works															
NB03290	NB70- NB post & panel installation	0%	5	5	20-Dec-16	24-Dec-16	689								
North Buffer Zone 2 (NBZ2) (within Zone 4) (Ch. 7925 to 8100)															
Bridge Construction															

Activity ID	Activity Name	Dur. % Complete	Rem. Duration	Original Duration	Start	Finish	Total Float	2016				2017			
								Dec		Jan		Feb		Mar	
New Ho Ka Yuen Footbridge															
TWSR-West/ FL Highway N/B Side Section															
HKY1250	HKYAB3 - pile cap & abutment wall	63.53%	31	85	20-Aug-16 A	27-Jan-17	653								
HKY1260	HKYAB3 - Backfilling (~4m)	0%	12	12	06-Feb-17	18-Feb-17	653								
HKY1270	Steel Staircase ready for erection (THFB-TWSR-W side)	0%	0	0		18-Feb-17	653								
HKY1273	Erect Staircase (HKY-TWSR-W side)	0%	30	30	20-Feb-17	25-Mar-17	653								
HKY1440	Remaining Finishes works of HKYFB	16%	126	150	21-Nov-16 A	03-Jun-17	555								
TWSR-East FL Highway S/B Side Section															
HKY1870	Steel Ramp finishes work (HKYFB-TWSR-E side)	16.67%	30	36	13-Oct-16 A	26-Jan-17	696								
Other Works															
Slope Works															
TWSR-East FL Highway S/B Side Section															
S1000	Slope S51-Fill ~3m	0%	40	40	20-Dec-16	15-Feb-17	590								
ZONE 4 (Ch. 7925 to 8700)															
Noise Barrier Along Fanling Highway N/B															
NB75 (Ch.7930-8090)-FH N/B Side															
Noise Barrier Works															
NB4040	NB75 -Pre-drilling (Ch7930-7990)	45.83%	13	24	28-Nov-16 A	06-Jan-17	0								
NB4050	NB75 - piling (NB75/01-05, 0.19m -24no)	0%	48	48	07-Jan-17	11-Mar-17	0								
NB4060	NB75 - Footing & Wall Structure (Ch7930-7990)	0%	60	60	13-Mar-17	27-May-17	21								
NB4100	NB75 -Pre-drilling (Ch7990-8000)-(HKY-P1) & G34	0%	24	24	07-Jan-17	11-Feb-17	62								
NB4110	NB75 - piling (NB75/06, 0.19m -4no) & G34 (10 nos)	0%	21	21	13-Mar-17	06-Apr-17	38								
NB4160	NB75 -Pre-drilling (Ch8000-8050)	0%	48	48	07-Jan-17	11-Mar-17	0								
NB4170	NB75 - piling (NB75/07-10, 0.19m -20no)	0%	32	32	13-Mar-17	22-Apr-17	0								
NB4220	NB75 -Pre-drilling (Ch8050-8090)	0%	42	42	01-Mar-17	22-Apr-17	14								
NB77 (Ch.8090-8450)-FH N/B Side															
Noise Barrier Works															
NB4290	NB77 -Pre-drilling (Ch8090-8190)	0%	24	24	01-Dec-16 A	19-Jan-17	7								
NB4300	NB77 - piling (NB77/01-08, 0.19m -34no)	0%	68	68	09-Jan-17	06-Apr-17	7								
NB4350	NB77 -Pre-drilling (Ch8190-8290)	0%	72	72	20-Dec-16	24-Mar-17	27								
NB4360	NB77 - piling (NB77/09-17, 0.19m -36no)	0%	72	72	04-Mar-17	03-Jun-17	27								
NB4410	NB77 -Pre-drilling (Ch8290-8390)	0%	60	60	20-Jan-17	08-Apr-17	21								
Bridge Construction															
New Wo Hop Shek Pedstrian & Cycle Bridge															
TWSR-West/ FL Highway N/B Side Section															
WHS1300	Existing WHS bridge structure removed	0%	0	0		10-Mar-17	268								
WHS1350	WHSAB2 - Predrilling (VO018)	0%	24	24	11-Mar-17	08-Apr-17	268								
Demolition of Existing Wo Hop Shek Pedstrian & Cycle Bridge															
TWSR-West/ FL Highway N/B Side Section															
WHS1870	Install Temp support to remove existing ramp	0%	25	25	20-Dec-16	20-Jan-17	268								
WHS1880	Remove existing ramp for 2nd half new ramp construction	0%	35	35	21-Jan-17	10-Mar-17	268								
WHS1890	Demolish existing WHS footbridge (TWSR-W side)	0%	30	30	20-Dec-16	26-Jan-17	530								
WHS2030	Remove temp filled platform	0%	30	30	27-Jan-17	10-Mar-17	530								
Crossing Fanling Highway Section															
WHS1790	Erect Temp platform for bridge demolition	7.5%	37	40	17-Oct-16 A	11-Feb-17	413								
WHS1800	Demolish existing WHS Footbridge	0%	60	60	13-Feb-17	27-Apr-17	413								
TWSR-East FL Highway S/B Side Section															
WHS1840	Demolish existing WHS Footbridge abutment wall at W77A	0%	20	20	20-Dec-16	14-Jan-17	4								
Slip Road Y Construction															
Drainage & Road Works															
TWSR-East FL Highway S/B Side Section															
RDZ41085	Construct Slip Rd Y (Ch7925-8050)(SA346) - remaining	0%	150	150	20-Dec-16	03-Jul-17	364								
Underground Utility Works															
DN600 and DN900 Watermain															
DN1070	DN600 watermain laying (Ch8400 - 8600) (W77A to	0%	280	280	28-Feb-17	05-Feb-18	34								
VO - Wall 76A Construction															
Retaining Wall W76A															
TWSR-East FL Highway S/B Side Section															
W76A1050	Drainage work for Caltex access road	0%	150	150	20-Dec-16	03-Jul-17	426								
Fanling Highway Construction															
Drainage & Road Works															
TWSR-East FL Highway S/B Side Section															
RDZ41086	Construct FH S/B Lane 1 & 2 (Ch7925-8000)(SA346) (after HKY	0%	145	145	20-Dec-16	26-Jun-17	238								
Other Works															
Retaining Wall W77A															
TWSR-East FL Highway S/B Side Section															
RWZ4.1075	Temp Shoring & Excavation	0%	45	45	16-Jan-17	16-Mar-17	4								
RWZ4.1080	Base slab & Wall (3-7m high)-RW77A (Ch.0-20)	0%	90	90	27-Jan-17	26-May-17	4								
RWZ4.1140	Base slab & Wall (0-3m high)-RW77A (Ch.92-120)	91.8%	5	61	13-Sep-16 A	24-Dec-16	64								
RWZ4.1150	Backfilling (0-3m) - RW77A (Ch.92-120)	0%	30	30	28-Dec-16	09-Feb-17	64								
RWZ4.1160	CLP 132kV cable diversion	46.3%	29	54	15-Nov-16 A	25-Jan-17	34								
RWZ4.1170	Base slab & Wall (0-3m high)-RW77A last 1 bay at CH120	0%	21	21	26-Jan-17	27-Feb-17	34								
RWZ4.1180	DN600 pipe installation ready to start	0%	0	0	28-Feb-17		34								
Retaining Wall W77B															
TWSR-East FL Highway S/B Side Section															
RWZ4.1100	Base slab & Wall (0-3m high)-RW77B (Ch 0-23)	0%	60	60	20-Dec-16	10-Mar-17	24								

Activity ID	Activity Name	Dur. % Complete	Rem. Duration	Original Duration	Start	Finish	Total Float	2016				2017				
								Dec				Jan			Feb	Mar
RWZ4.1110	Backfilling (0-3m) - RW77B (Ch 0-23)	0%	30	30	11-Mar-17	19-Apr-17	24									
RWZ4.1115	Temp Shoring & Excavation	92.86%	15	210	01-Mar-16 A	09-Jan-17	104									
RWZ4.1120	Base slab & Wall (3-4m high)- RW77B (Ch.23-75)	76.65%	39	167	01-Jun-16 A	14-Feb-17	75									
Retaining Wall W78																
TWSR-East FL Highway S/B Side Section																
RWZ4.0900	Site Clearance	0%	30	30	10-Jan-17	21-Feb-17	104									
TCSS Works																
TCSS Pre-Construction Works																
TCSS0120	Prepare Shop Drawing-TCSS	0%	45	45	20-Dec-16	21-Feb-17	201									
TCSS0130	Shop Drawing Comment & Approval	0%	21	21	22-Feb-17	14-Mar-17	246									
TCSS0140	Revised & Re-submission TCSS shop Drawing	0%	18	18	15-Mar-17	04-Apr-17	200									
G35																
TCSS1550	Slip road island footing - G35 (CH8410, N/B)	0%	30	30	20-Dec-16	26-Jan-17	454									
FVMS2 (Deleted by RFI-138, Pending for VO)																
TCSS1640	Slow lane footing - FVMS2 (CH8400, S/B)- Deleted by RFI-138	0%	30	30	20-Dec-16	26-Jan-17	574									

**APPENDIX C
IMPLEMENTATION SCHEDULE OF
ENVIRONMENTAL MITIGATION MEASURES
(EMIS)**

Appendix C - Implementation Schedule of Environmental Mitigation Measures (EMIS)

Air Quality – Schedule of Recommended Mitigation Measures

Impact	Mitigation Measures	Timing	Implementation Status
Air Quality during construction	Restricting heights from which materials are dropped, as far as practicable to minimize the fugitive dust arising from unloading/loading.	During construction	V
	All stockpiles of excavated materials or spoil of more than 50m ³ shall be enclosed, covered or dampened during dry or windy conditions.		@
	Effective water sprays shall be used to control potential dust emission sources such as unpaved haul roads and active construction areas.		@
	All spraying of materials and surfaces shall avoid excessive water usage.		V
	Vehicles that have the potential to create dust while transporting materials shall be covered, with the cover properly secured and extended over the edges of the side and tail boards.		V
	Materials shall be dampened, if necessary, before transportation.		V
	Travelling speeds shall be controlled to reduce traffic induced dust dispersion and re-suspension within the site from the operating haul trucks.		V
	Vehicle washing facilities shall be provided to minimize the quantity of material deposited on public roads.		V

Noise – Schedule of Recommended Mitigation Measures

Impact	Mitigation Measures	Timing	Implementation Status
Noise during construction	Use of silenced plant or plant equipped with mufflers or dampers in substitute of ordinary plant.	During construction	V
	Reduce the number of equipment and their percentage on-time.		V
	3.5 m and 5.5 m high temporary noise barrier at culvert construction work area (Figure 2a of the Environmental Permit).		V
	3 m high temporary noise barrier along the northern edge of Bridge 12 at ground level (Figure 2b of the Environmental Permit).		V
	2 m high temporary noise barrier along the northern edge of Bridge 12 at bridge level (Figure 2b of the Environmental Permit).		V
	2.5 m high temporary noise barrier along Tai Wo Service Road West (Figure 2c of the Environmental Permit).		V
	3.5m and 7m high temporary noise barrier along Tai Wo Services Road West near Tai Hang (Figure 2c of the Environmental Permit).		V
	7 m high temporary noise barrier along Tai Wo Service Road West near Tai Wo Footbridge work area (Figure 2d of the Environmental Permit).		V
	7 m high temporary noise barrier near Kiu Tau Footbridge work area (Figure 2d of the Environmental Permit).		V
	2.5 m high temporary noise barrier near river diversion work area (Figure 2e of the Environmental Permit).		N.A.

Water Quality – Schedule of Recommended Mitigation Measures

Impact	Mitigation Measures	Timing	Implementation Status
Water quality during construction	Demolition and reconstruction of bridges <ul style="list-style-type: none"> - Prevent off-site migration through use of sheet piles. - Minimise duration of works as far as practical. - All sewer and drainage connections should be sealed to prevent debris, soil, sand, etc, from entering public sewers/drains. - Site surface runoff should be settled to remove sand/silt before it is discharged into the existing storm drains. 	During construction	V
	Road Widening Works, Earthworks and Culvert Extension Works <ul style="list-style-type: none"> - Wastewater generated from any concrete batching washdown of equipment or similar activities should be discharged into foul sewers, after the removal of settleable solids, and pH adjustment as necessary. All sewage discharges from the study area should meet the TM standards and approval from EPD through the licensing process is required. - Sand traps, oil interceptors and other pollution prevention installations should be provided, properly cleaned and maintained. - Runoff from exposed working areas, unfinished slopes and from unlined temporary channels should be directed to stilling basins and/or silt traps before discharging to the drainage outfalls. - Regular inspections of stilling basins and/or silt traps are required to ensure that sediment is not conveyed into the existing drainage system. - Open stockpiles should be covered with a tarpaulin cover. - During the wet season, any exposed top soils should be covered with a tarpaulin, shotcreted or hydroseeded. - Sand and silt from wash-water from vehicle washing should be settled out before discharging into storm drains. - Fuels should be stored in bunded areas such that spillage can be easily collected. 		@

Waste – Schedule of Recommended Mitigation Measures

Impact	Mitigation Measures	Timing	Implementation Status
Waste management during construction	General Waste <ul style="list-style-type: none"> - Transport of wastes off site as soon as possible. - Maintenance of accurate waste records. - Minimisation of waste generation for disposal (via reduction/recycling/re-use). - No on-site burning will be permitted. - Use of re-useable metal hoardings/signboards. 	During construction	@
	Vegetation from site clearance <ul style="list-style-type: none"> - Segregation of materials to facilitate disposal. - Mulching to reduce bulk and where possible review opportunities for the possible beneficial use within landscaping areas. 		V
	Demolition Wastes <ul style="list-style-type: none"> - Segregation of materials to facilitate disposal. - Appropriate stockpile management. 		V
	Excavated Materials <ul style="list-style-type: none"> - Segregation of materials to facilitate disposal / reuse. - Appropriate stockpile management. - Re-use of excavated material on or off site (where possible). - Special handling and disposal procedures in the event that contaminated materials are excavated. 		V
	Construction Wastes <ul style="list-style-type: none"> - Segregation of materials to facilitate recycling/reuse (within designated area in appropriate containers/stockpiles). - Appropriate stockpile management. - Planning to reduce over ordering and waste generation. - Recycling and re-use of materials where possible (e.g. metal, wood from formwork) - For material which cannot be re-used/recycled, collection should be carried out by an approved waste contractor for landfill disposal. 		@
	Bentonite Slurries <ul style="list-style-type: none"> - Bentonite slurries should be reused as far as possible. - Disposal in accordance with Practice Note For Professional Persons ProPECC PN 1/94. 		#

	<p>Chemical Wastes</p> <ul style="list-style-type: none"> - Storage within locked, covered and bunded area. - The storage area shall not be located adjacent to sensitive receivers e.g. drains. - Minimise waste production and recycle oils/solvents where possible. - A spill response procedure shall be in place and absorption material available for minor spillages. - Use appropriate and labelled containers. - Educate site workers on site cleanliness/waste management procedures. - If chemical wastes are to be generated, the contractor must register with EPD as a chemical waste producer. - The chemical wastes shall be collected by a licensed chemical waste collector. 		<p>@</p>
	<p>Municipal Wastes</p> <ul style="list-style-type: none"> - Waste shall be stored within a temporary refuse collection facility, in appropriate containers prior to collection and disposal. - Regular, daily collections are required by an approved waste collector. 		<p>@</p>

Ecology – Schedule of Recommended Mitigation Measures

Impact	Mitigation Measures	Timing	Implementation Status
Ecology during construction	<p>Accurate Delineation of Works Area</p> <ul style="list-style-type: none"> - Boundaries of proposed works areas shall be clearly identified and separated from external areas by a physical barrier to prevent encroachment of adjacent habitats. - Individual trees which fall within the works areas but which work plans do not require removal are to be retained and fenced off to maximize protection. 	During construction	V
	<p>Vegetation Clearance</p> <ul style="list-style-type: none"> - No fires shall be lit within the works area for the purpose of burning cleared vegetation. - The Contractor shall give consideration to mulching the cleared vegetation for recycling within the works area / adjacent land. 		V
	<p>Dust generation</p> <p>There are a number of measures which shall be taken as specified in the Air Pollution Control (Construction Dust) Regulation on 'Dust Control Requirements, including the following key measures to be applied during construction:</p> <ul style="list-style-type: none"> - Vehicle washing facilities to be provided at every discernible or designated vehicle exit point; - All temporary site access roads shall be sprayed with water to suppress dust as necessary; - All dusty materials should be sprayed with water immediately prior to any handling; and - All debris should be covered entirely by impervious sheeting or stored in a sheltered debris collection area. 		@
	<p>Surface Run-off</p> <p>In general, mitigation measures shall be in accordance with ProPECC PN1/94 on 'Construction Site Drainage'. Key measures include:</p> <ul style="list-style-type: none"> - Bund and cover stock piles to avoid run-off; - Channel any run-off through a system of oil, grease and sediment / silt traps and reuse water on site where ever practical; - All vehicle maintenance to be undertaken within a bunded area; and - Maximise vegetation retention on-site to maximise absorption (minimise transport). 		V

Landscape and Visual Impact – Schedule of Recommended Mitigation Measures

Impact	Mitigation Measures	Timing	Responsibility
Landscape & Visual during construction	Preservation of Existing Vegetation - Trees identified for retention within the project limit would be protected during the works; - The tree transplanting and planting works shall be implemented by approved Landscape Contractors.	During construction	V
	Temporary Works Areas - Where feasible the works areas would be screened using hoarding and existing vegetation would be retained where possible to reduce the landscape and visual impacts arising from the construction activity. The landscape of these works areas would be restored following the completion of the construction phase.		V
	Hoarding - A hoarding would be erected where practicable in the most visually sensitive locations to screen the temporary construction works from the local VSRs.		V
	Top Soils - The works will result in disturbance to extensive areas of topsoil. Topsoil worthy of retention should be stockpiled for use following completion of the civil engineering works. It should either be temporarily vegetated with hydroseeded grass or turned over on a regular basis.		#
	Protection of Important Landscape Features - Important features such as temples, Island House and kilns within the study area, although remote from the proposed works retained and adequately protected.		#

Legend:

V = implemented;

x = not implemented;

@ = partially implemented;

+ = recommended and immediately implemented during the site inspection by the Contractor;

N/A = not applicable - No such work was undertaken or no such material was used on site;

= to be implemented.

**APPENDIX D
SUMMARY OF ACTION AND LIMIT LEVELS**

Appendix D - Summary of Action and Limit Levels

Table 1 – Action and Limit Levels for 1-hour TSP

Location	Action Level	Limit Level
AM2	317.8 µg/m ³	500 µg/m ³

Table 2 – Action and Limit Levels for 24-hour TSP

Location	Action Level	Limit Level
AM2	200.7 µg/m ³	260 µg/m ³

Table 3 – Action and Limit Levels for Construction Noise (0700-1900 hrs of normal weekdays)

Location	Action Level	Limit Level
M2	When one documented complaint, related to 0700 – 1900 hours on normal weekdays, is received from any one of the sensitive receivers	75 dB(A)
M3*		65/70 dB(A)

*Daytime noise Limit Level of 70 dB(A) applies to education institutions, while 65dB(A) applies during school examination period

**APPENDIX E
CALIBRATION CERTIFICATES OF
MONITORING EQUIPMENTS**



TISCH ENVIRONMENTAL, INC.
 145 SOUTH MIAMI AVE
 VILLAGE OF CLEVELAND, OH
 45002
 513.467.9000
 877.263.7610 TOLL FREE
 513.467.9009 FAX

ORIFICE TRANSFER STANDARD CERTIFICATION WORKSHEET TE-5025A

Date - May 31, 2016 Rootmeter S/N 0438320 Ta (K) - 298
 Operator Tisch Orifice I.D. - 0988 Pa (mm) - 754.38

PLATE OR Run #	VOLUME START (m3)	VOLUME STOP (m3)	DIFF VOLUME (m3)	DIFF TIME (min)	METER	ORFICE
					DIFF Hg (mm)	DIFF H2O (in.)
1	NA	NA	1.00	1.3670	3.2	2.00
2	NA	NA	1.00	0.9750	6.4	4.00
3	NA	NA	1.00	0.8700	7.9	5.00
4	NA	NA	1.00	0.8260	8.7	5.50
5	NA	NA	1.00	0.6830	12.7	8.00

DATA TABULATION

Vstd	(x axis) Qstd	(y axis)	Va	(x axis) Qa	(y axis)
0.9884	0.7230	1.4090	0.9957	0.7284	0.8888
0.9842	1.0094	1.9926	0.9915	1.0170	1.2570
0.9821	1.1289	2.2278	0.9894	1.1373	1.4054
0.9811	1.1878	2.3365	0.9884	1.1967	1.4740
0.9758	1.4288	2.8179	0.9831	1.4394	1.7777
Qstd slope (m) = 1.99349			Qa slope (m) = 1.24829		
intercept (b) = -0.02737			intercept (b) = -0.01727		
coefficient (r) = 0.99988			coefficient (r) = 0.99988		
y axis = SQRT[H2O(Pa/760)(298/Ta)]			y axis = SQRT[H2O(Ta/Pa)]		

CALCULATIONS

Vstd = Diff. Vol [(Pa-Diff. Hg)/760] (298/Ta)
 Qstd = Vstd/Time

Va = Diff Vol [(Pa-Diff Hg)/Pa]
 Qa = Va/Time

For subsequent flow rate calculations:

Qstd = 1/m{ [SQRT(H2O(Pa/760)(298/Ta))] - b}
 Qa = 1/m{ [SQRT H2O(Ta/Pa)] - b}

EQUIPMENT CALIBRATION RECORD

Type: Laser Dust Monitor
 Manufacturer/Brand: SIBATA
 Model No.: LD-3
 Equipment No.: A.005.07a
 Sensitivity Adjustment Scale Setting: 557 CPM
 Operator: Mike Shek (MSKM)

Standard Equipment

Equipment: Rupprecht & Patashnick TEOM®
 Venue: Cyberport (Pui Ying Secondary School)
 Model No.: Series 1400AB
 Serial No: Control: 140AB219899803
 Sensor: 1200C143659803 K_o: 12500
 Last Calibration Date*: 7 May 2016

*Remarks: Recommended interval for hardware calibration is 1 year

Calibration Result

Sensitivity Adjustment Scale Setting (Before Calibration): 557 CPM
 Sensitivity Adjustment Scale Setting (After Calibration): 557 CPM

Hour	Date (dd-mm-yy)	Time	Ambient Condition		Concentration ¹ (mg/m ³) Y-axis	Total Count ²	Count/ Minute ³ X-axis
			Temp (°C)	R.H. (%)			
1	07-05-16	12:15 - 13:15	28.1	77	0.04530	1812	30.20
2	07-05-16	13:15 - 14:15	28.2	76	0.04659	1863	31.05
3	07-05-16	14:15 - 15:15	28.4	78	0.04560	1824	30.40
4	07-05-16	15:15 - 16:15	28.5	77	0.04434	1774	29.57

Note: 1. Monitoring data was measured by Rupprecht & Patashnick TEOM®
 2. Total Count was logged by Laser Dust Monitor
 3. Count/minute was calculated by (Total Count/60)

By Linear Regression of Y or X

Slope (K-factor): 0.0015
 Correlation coefficient: 0.9969

Validity of Calibration Record: 7 May 2017

Remarks:

QC Reviewer: YW Fung Signature:  Date: 09 May 2016

EQUIPMENT CALIBRATION RECORD

Type: Laser Dust Monitor
 Manufacturer/Brand: SIBATA
 Model No.: LD-3
 Equipment No.: A.005.09a
 Sensitivity Adjustment Scale Setting: 797 CPM

Operator: Mike Shek (MSKM)

Standard Equipment

Equipment: Rupprecht & Patashnick TEOM®
 Venue: Cyberport (Pui Ying Secondary School)
 Model No.: Series 1400AB
 Serial No: Control: 140AB219899803
 Sensor: 1200C143659803 Ko: 12500
 Last Calibration Date*: 7 May 2016

*Remarks: Recommended interval for hardware calibration is 1 year

Calibration Result

Sensitivity Adjustment Scale Setting (Before Calibration): 797 CPM
 Sensitivity Adjustment Scale Setting (After Calibration): 797 CPM

Hour	Date (dd-mm-yy)	Time	Ambient Condition		Concentration ¹ (mg/m ³) Y-axis	Total Count ²	Count/ Minute ³ X-axis
			Temp (°C)	R.H. (%)			
1	07-05-16	11:45 - 12:45	28.2	77	0.04623	1847	30.78
2	07-05-16	12:45 - 13:45	28.2	78	0.04708	1885	31.42
3	07-05-16	13:45 - 14:45	28.3	76	0.04591	1836	30.60
4	07-05-16	14:45 - 15:45	28.4	77	0.04333	1726	28.77

Note: 1. Monitoring data was measured by Rupprecht & Patashnick TEOM®
 2. Total Count was logged by Laser Dust Monitor
 3. Count/minute was calculated by (Total Count/60)

By Linear Regression of Y or X

Slope (K-factor): 0.0015
 Correlation coefficient: 0.9964

Validity of Calibration Record: 7 May 2017

Remarks:

QC Reviewer: YW Fung Signature:  Date: 09 May 2016



CERTIFICATE OF CALIBRATION

Certificate No.: 16CA0704 03-01 Page 1 of 2

Item tested

Description:	Sound Level Meter (Type 1)	Microphone
Manufacturer:	B & K	B & K
Type/Model No.:	2238	4188
Serial/Equipment No.:	2800927 / N.009.06	2791211
Adaptors used:	-	-

Item submitted by

Customer Name: AECOM ASIA CO., LTD.
Address of Customer: -
Request No.: -
Date of receipt: 04-Jul-2016

Date of test: 07-Jul-2016

Reference equipment used in the calibration

Description:	Model:	Serial No.	Expiry Date:	Traceable to:
Multi function sound calibrator	B&K 4226	2288444	18-Jun-2017	CIGISMEC
Signal generator	DS 360	33873	18-Apr-2017	CEPREI
Signal generator	DS 360	61227	18-Apr-2017	CEPREI

Ambient conditions

Temperature: 22 ± 1 °C
Relative humidity: 60 ± 10 %
Air pressure: 1000 ± 5 hPa

Test specifications

- 1, The Sound Level Meter has been calibrated in accordance with the requirements as specified in BS 7580: Part 1: 1997 and the lab calibration procedure SMTP004-CA-152.
- 2, The electrical tests were performed using an electrical signal substituted for the microphone which was removed and replaced by an equivalent capacitance within a tolerance of $\pm 20\%$.
- 3, The acoustic calibration was performed using an B&K 4226 sound calibrator and corrections was applied for the difference between the free-field and pressure responsiveness of the Sound Level Meter.

Test results

This is to certify that the Sound Level Meter conforms to BS 7580: Part 1: 1997 for the conditions under which the test was performed.

Details of the performed measurements are presented on page 2 of this certificate.

Actual Measurement data are documented on worksheets.

Approved Signatory:

Huang Jian Min/Feng Jun Qi

Date: 09-Jul-2016

Company Chop:



Comments: The results reported in this certificate refer to the condition of the instrument on the date of calibration and carry no implication regarding the long-term stability of the instrument.



CERTIFICATE OF CALIBRATION

(Continuation Page)

Certificate No.: 16CA0704 03-01 Page 2 of 2

1, Electrical Tests

The electrical tests were performed using an equivalent capacitance substituted for the microphone. The results are given in below with test status and the estimated uncertainties. The "Pass" means the result of the test is inside the tolerances stated in the test specifications. The "-" means the result of test is outside these tolerances.

Test:	Subtest:	Status:	Expanded Uncertainty (dB)	Coverage Factor
Self-generated noise	A	Pass	0.3	
	C	Pass	1.0	2.1
	Lin	Pass	2.0	2.2
Linearity range for Leq	At reference range, Step 5 dB at 4 kHz	Pass	0.3	
	Reference SPL on all other ranges	Pass	0.3	
	2 dB below upper limit of each range	Pass	0.3	
	2 dB above lower limit of each range	Pass	0.3	
Linearity range for SPL	At reference range, Step 5 dB at 4 kHz	Pass	0.3	
	Frequency weightings			
Time weightings	A	Pass	0.3	
	C	Pass	0.3	
	Lin	Pass	0.3	
Peak response	Single Burst Fast	Pass	0.3	
	Single Burst Slow	Pass	0.3	
R.M.S. accuracy	Single 100µs rectangular pulse	Pass	0.3	
	Crest factor of 3	Pass	0.3	
Time weighting I	Single burst 5 ms at 2000 Hz	Pass	0.3	
	Repeated at frequency of 100 Hz	Pass	0.3	
Time averaging	1 ms burst duty factor 1/10 ³ at 4kHz	Pass	0.3	
	1 ms burst duty factor 1/10 ⁴ at 4kHz	Pass	0.3	
Pulse range	Single burst 10 ms at 4 kHz	Pass	0.4	
Sound exposure level	Single burst 10 ms at 4 kHz	Pass	0.4	
Overload indication	SPL	Pass	0.3	
	Leq	Pass	0.4	

2, Acoustic tests

The complete sound level meter was calibrated on the reference range using a B&K 4226 acoustic calibrator with 1000Hz and SPL 94 dB. The sensitivity of the sound level meter was adjusted. The test result at 125 Hz and 8000 Hz are given in below with test status and the estimated uncertainties.

Test:	Subtest	Status	Expanded Uncertainty (dB)	Coverage Factor
Acoustic response	Weighting A at 125 Hz	Pass	0.3	
	Weighting A at 8000 Hz	Pass	0.5	

3, Response to associated sound calibrator

N/A

The expanded uncertainties have been calculated in accordance with the ISO Publication "Guide to the expression of uncertainty in measurement", and gives an interval estimated to have a level of confidence of 95%. A coverage factor of 2 is assumed unless explicitly stated.

- End -

Calibrated by:
Date: 07-Jul-2016

Checked by:
Date: 09-Jul-2016

The standard(s) and equipment used in the calibration are traceable to national or international recognised standards and are calibrated on a schedule to maintain the required accuracy level.



CERTIFICATE OF CALIBRATION

Certificate No.: 16CA0408 02 Page 1 of 2

Item tested

Description:	Sound Level Meter (Type 1)	,	Microphone
Manufacturer:	B & K	,	B & K
Type/Model No.:	2238	,	4188
Serial/Equipment No.:	2285692	,	2791211
Adaptors used:	-	,	-

Item submitted by

Customer Name: AECOM ASIA CO., LTD.
Address of Customer: -
Request No.: -
Date of receipt: 08-Apr-2016

Date of test: 11-Apr-2016

Reference equipment used in the calibration

Description:	Model:	Serial No.	Expiry Date:	Traceable to:
Multi function sound calibrator	B&K 4226	2288444	19-Jun-2016	CIGISMEC
Signal generator	DS 360	33873	16-Apr-2016	CEPREI
Signal generator	DS 360	61227	16-Apr-2016	CEPREI

Ambient conditions

Temperature: 21 ± 1 °C
Relative humidity: 50 ± 10 %
Air pressure: 1010 ± 5 hPa

Test specifications

- 1, The Sound Level Meter has been calibrated in accordance with the requirements as specified in BS 7580: Part 1: 1997 and the lab calibration procedure SMTP004-CA-152.
- 2, The electrical tests were performed using an electrical signal substituted for the microphone which was removed and replaced by an equivalent capacitance within a tolerance of $\pm 20\%$.
- 3, The acoustic calibration was performed using an B&K 4226 sound calibrator and corrections was applied for the difference between the free-field and pressure responsiveness of the Sound Level Meter.

Test results

This is to certify that the Sound Level Meter conforms to BS 7580: Part 1: 1997 for the conditions under which the test was performed.

Details of the performed measurements are presented on page 2 of this certificate.

Actual Measurement data are documented on worksheets.

Approved Signatory:

Huang Jian Min/Feng Jun Qi

Date: 12-Apr-2016

Company Chop:



Comments: The results reported in this certificate refer to the condition of the instrument on the date of calibration and carry no implication regarding the long-term stability of the instrument.



CERTIFICATE OF CALIBRATION

(Continuation Page)

Certificate No.: 16CA0408 02 Page 2 of 2

1, Electrical Tests

The electrical tests were performed using an equivalent capacitance substituted for the microphone. The results are given in below with test status and the estimated uncertainties. The "Pass" means the result of the test is inside the tolerances stated in the test specifications. The "-" means the result of test is outside these tolerances.

Test:	Subtest:	Status:	Expanded Uncertainty (dB)	Coverage Factor
Self-generated noise	A	Pass	0.3	
	C	Pass	1.0	2.1
	Lin	Pass	2.0	2.2
Linearity range for Leq	At reference range , Step 5 dB at 4 kHz	Pass	0.3	
	Reference SPL on all other ranges	Pass	0.3	
	2 dB below upper limit of each range	Pass	0.3	
	2 dB above lower limit of each range	Pass	0.3	
Linearity range for SPL	At reference range , Step 5 dB at 4 kHz	Pass	0.3	
	A	Pass	0.3	
	C	Pass	0.3	
	Lin	Pass	0.3	
Time weightings	Single Burst Fast	Pass	0.3	
	Single Burst Slow	Pass	0.3	
Peak response	Single 100µs rectangular pulse	Pass	0.3	
	R.M.S. accuracy	Crest factor of 3	Pass	0.3
Time weighting I	Single burst 5 ms at 2000 Hz	Pass	0.3	
	Repeated at frequency of 100 Hz	Pass	0.3	
Time averaging	1 ms burst duty factor 1/10 ³ at 4kHz	Pass	0.3	
	1 ms burst duty factor 1/10 ⁴ at 4kHz	Pass	0.3	
Pulse range	Single burst 10 ms at 4 kHz	Pass	0.4	
Sound exposure level	Single burst 10 ms at 4 kHz	Pass	0.4	
Overload indication	SPL	Pass	0.3	
	Leq	Pass	0.4	

2, Acoustic tests

The complete sound level meter was calibrated on the reference range using a B&K 4226 acoustic calibrator with 1000Hz and SPL 94 dB. The sensitivity of the sound level meter was adjusted. The test result at 125 Hz and 8000 Hz are given in below with test status and the estimated uncertainties.

Test:	Subtest	Status	Expanded Uncertainty (dB)	Coverage Factor
Acoustic response	Weighting A at 125 Hz	Pass	0.3	
	Weighting A at 8000 Hz	Pass	0.5	

3, Response to associated sound calibrator

N/A

The expanded uncertainties have been calculated in accordance with the ISO Publication "Guide to the expression of uncertainty in measurement", and gives an interval estimated to have a level of confidence of 95%. A coverage factor of 2 is assumed unless explicitly stated.

Calibrated by:

Fung Chi Yip
Date: 11-Apr-2016

- End -

Checked by:

Lam Tze Wai
Date: 12-Apr-2016

The standard(s) and equipment used in the calibration are traceable to national or international recognised standards and are calibrated on a schedule to maintain the required accuracy level.



CERTIFICATE OF CALIBRATION

Certificate No.: 16CA1201 01

Page: 1 of 2

Item tested

Description: Acoustical Calibrator (Class 1)
Manufacturer: Rion Co., Ltd.
Type/Model No.: NC-73
Serial/Equipment No.: 10307223 (CN.004.08)
Adaptors used: -

Item submitted by

Customer: AECOM ASIA CO. LTD.
Address of Customer: -
Request No.: -
Date of receipt: 01-Dec-2016

Date of test: 05-Dec-2016

Reference equipment used in the calibration

Description:	Model:	Serial No.	Expiry Date:	Traceable to:
Lab standard microphone	B&K 4180	2412857	14-Apr-2017	SCL
Preamplifier	B&K 2673	2239857	28-Apr-2017	CEPREI
Measuring amplifier	B&K 2610	2346941	26-Apr-2017	CEPREI
Signal generator	DS 360	61227	18-Apr-2017	CEPREI
Digital multi-meter	34401A	US36087050	18-Apr-2017	CEPREI
Audio analyzer	8903B	GB41300350	19-Apr-2017	CEPREI
Universal counter	53132A	MY40003662	19-Apr-2017	CEPREI

Ambient conditions

Temperature: 22 ± 1 °C
Relative humidity: 55 ± 10 %
Air pressure: 1005 ± 5 hPa

Test specifications

- The Sound Calibrator has been calibrated in accordance with the requirements as specified in IEC 60942 1997 Annex B and the lab calibration procedure SMTP004-CA-156.
- The calibrator was tested with its axis vertical facing downwards at the specific frequency using insert voltage technique.
- The results are rounded to the nearest 0.01 dB and 0.1 Hz and have not been corrected for variations from a reference pressure of 1013.25 hectoPascals as the maker's information indicates that the instrument is insensitive to pressure changes.

Test results

This is to certify that the sound calibrator conforms to the requirements of annex B of IEC 60942: 1997 for the conditions under which the test was performed. This does not imply that the sound calibrator meets IEC 60942 under any other conditions.

Details of the performed measurements are presented on page 2 of this certificate.

Approved Signatory:

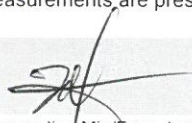
Huang Jian Min / Feng Jun Qi

Date: 08-Dec-2016

Company Chop:

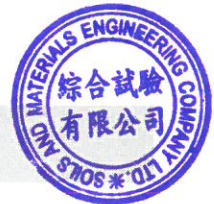

Comments: The results reported in this certificate refer to the condition of the instrument on the date of calibration and carry no implication regarding the long-term stability of the instrument.



CERTIFICATE OF CALIBRATION

(Continuation Page)

Certificate No.: 16CA1201 01 Page: 2 of 2

1, Measured Sound Pressure Level

The output Sound Pressure Level in the calibrator head was measured at the setting and frequency shown using a calibrated laboratory standard microphone and insert voltage technique. The results are given in below with the estimated uncertainties.

Frequency Shown Hz	Output Sound Pressure Level Setting dB	Measured Output Sound Pressure Level dB	Estimated Expanded Uncertainty dB
1000	94.00	94.22	0.10

(Output level in dB re 20 µPa)

2, Sound Pressure Level Stability - Short Term Fluctuations

The Short Term Fluctuations was determined by measuring the maximum and minimum of the fast weighted DC output of the B&K 2610 measuring amplifier over a 20 second time interval as required in the standard. The Short Term Fluctuation was found to be:

At 1000 Hz **STF = 0.002 dB**
 Estimated expanded uncertainty 0.005 dB

3, Actual Output Frequency

The determination of actual output frequency was made using a B&K 4180 microphone together with a B&K 2673 preamplifier connected to a B&K 2610 measuring amplifier. The AC output of the B&K 2610 was taken to an universal counter which was used to determine the frequency averaged over 20 second of operation as required by the standard. The actual output frequency at 1 KHz was:

At 1000 Hz **Actual Frequency = 986.6 Hz**
 Estimated expanded uncertainty 0.1 Hz Coverage factor k = 2.2

4, Total Noise and Distortion

For the Total Noise and Distortion measurement, the unfiltered AC output of the B&K 2610 measuring amplifier was connected to an Agilent Type 8903 B distortion analyser. The TND result at 1 KHz was:

At 1000 Hz **TND = 0.5 %**
 Estimated expanded uncertainty 0.7 %

The expanded uncertainties have been calculated in accordance with the ISO Publication "Guide to the expression of uncertainty in measurement", and gives an interval estimated to have a level of confidence of 95%. A coverage factor of 2 is assumed unless explicitly stated.

- End -

Calibrated by:

Fung Chi Yip

Date: 05-Dec-2016

Checked by:

Lam Tze Wai

Date: 08-Dec-2016

The standard(s) and equipment used in the calibration are traceable to national or international recognised standards and are calibrated on a schedule to maintain the required accuracy level.

**APPENDIX F
EM&A MONITORING SCHEDULES**

Contract No. HY/2012/06
Widening of Fanling Highway – Tai Hang to Wo Hop Shek Interchange
Impact Monitoring and Audit Schedule for January 2017

Sunday	Monday	Tuesday	Wednesday	Thursday	Friday	Saturday
1-Jan	2-Jan	3-Jan	4-Jan	5-Jan	6-Jan	7-Jan
		1-hr TSP 24-hr TSP Noise Site Audit				
8-Jan	9-Jan	10-Jan	11-Jan	12-Jan	13-Jan	14-Jan
	1-hr TSP 24-hr TSP Noise	Site Audit				1-hr TSP 24-hr TSP
15-Jan	16-Jan	17-Jan	18-Jan	19-Jan	20-Jan	21-Jan
				Site Audit	1-hr TSP 24-hr TSP Noise	
22-Jan	23-Jan	24-Jan	25-Jan	26-Jan	27-Jan	28-Jan
		Site Audit		1-hr TSP 24-hr TSP Noise		
29-Jan	30-Jan	31-Jan				

Contract No. HY/2012/06
Widening of Fanling Highway – Tai Hang to Wo Hop Shek Interchange
Tentative Impact Monitoring and Audit Schedule for February 2017

Sunday	Monday	Tuesday	Wednesday	Thursday	Friday	Saturday
			1-Feb	2-Feb	3-Feb	4-Feb
			1-hr TSP 24-hr TSP Noise		Site Audit	
5-Feb	6-Feb	7-Feb	8-Feb	9-Feb	10-Feb	11-Feb
	1-hr TSP 24-hr TSP Noise	Site Audit				1-hr TSP 24-hr TSP
12-Feb	13-Feb	14-Feb	15-Feb	16-Feb	17-Feb	18-Feb
				1-hr TSP 24-hr TSP Noise Site Audit		
19-Feb	20-Feb	21-Feb	22-Feb	23-Feb	24-Feb	25-Feb
		Site Audit	1-hr TSP 24-hr TSP Noise			
26-Feb	27-Feb	28-Feb				
		1-hr TSP 24-hr TSP Noise Site Audit				

The schedule is subject to change due to unforeseeable circumstances (e.g. adverse weather, etc)

**APPENDIX G
IMPACT AIR QUALITY MONITORING
RESULTS AND THEIR GRAPHICAL
PRESENTATION**

**Appendix G
Impact Air Quality Monitoring Results**

24-hour TSP Monitoring Results at Station AM2 (Fanling Government Secondary School)

Date	Weather Condition	Air Temp. (°C)	Atmospheric Pressure(hPa)	Flow Rate (m ³ /min.)		Av. flow (m ³ /min)	Total vol. (m ³)	Filter Weight (g)		Particulate weight(g)	Elapse Time		Sampling Time(hrs.)	Conc. (µg/m ³)	Action Level (µg/m ³)	Limit Level (µg/m ³)
				Initial	Final			Initial	Final		Initial	Final				
3-Jan-17	Sunny	20.0	1019.8	1.314	1.314	1.314	1892.2	2.7575	2.8608	0.1033	8106.03	8130.03	24.00	54.6	200.7	260
9-Jan-17	Sunny	20.6	1016.3	1.314	1.314	1.314	1892.2	2.7582	2.8703	0.1121	8130.03	8154.03	24.00	59.2	200.7	260
14-Jan-17	Cloudy	15.7	1017.9	1.314	1.314	1.314	1892.2	2.8172	2.9845	0.1673	8154.03	8178.03	24.00	88.4	200.7	260
20-Jan-17	Sunny	18.3	1022.4	1.314	1.314	1.314	1892.2	2.7963	2.9295	0.1332	8178.03	8202.03	24.00	70.4	200.7	260
26-Jan-17	Sunny	17.3	1024.3	1.314	1.314	1.314	1892.2	2.7521	2.8804	0.1283	8202.03	8226.03	24.00	67.8	200.7	260
													Average	68.1		
													Min	54.6		
													Max	88.4		

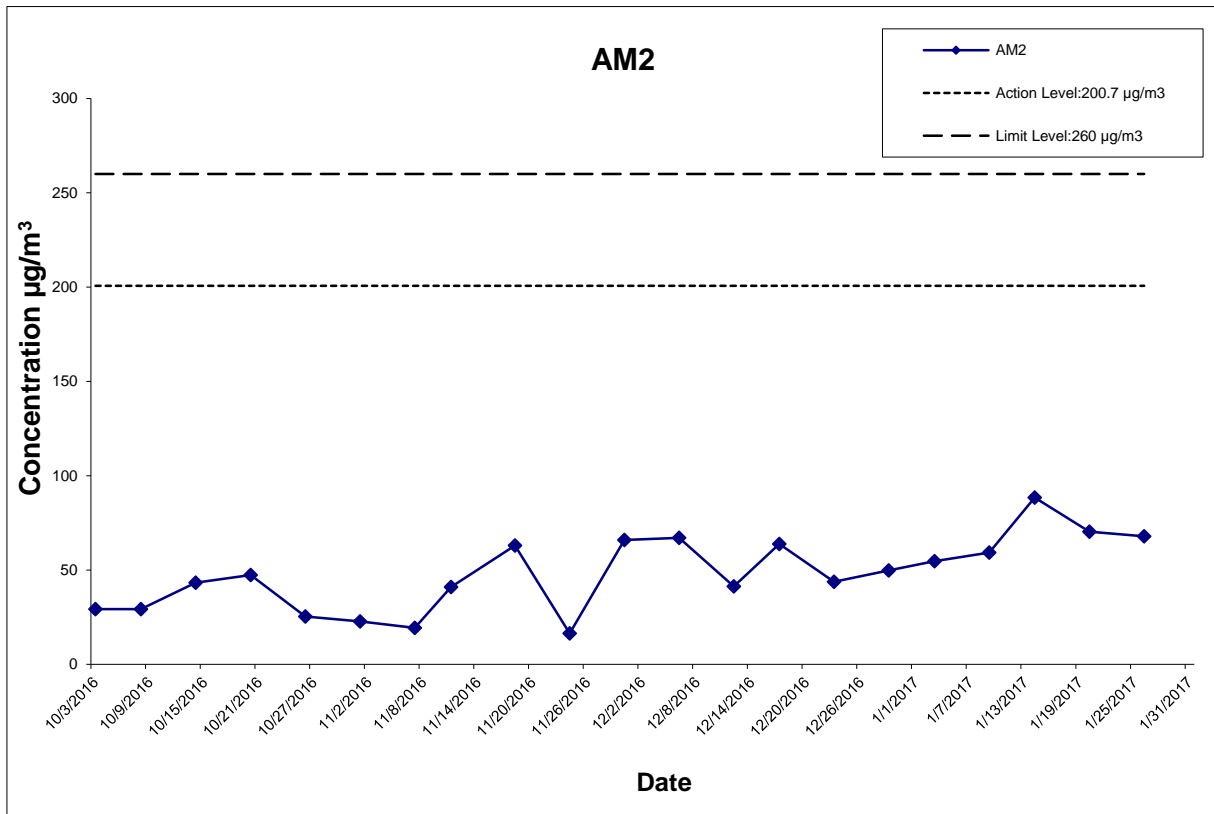

This Drawing has been prepared for the use of AECOM's client. It may not be used, modified, reproduced or relied upon by third parties, except as agreed by AECOM or as required by law. AECOM accepts no responsibility, and denies any liability whatsoever, to any party that uses or relies on this drawing without AECOM's express written consent.

CONTRACT NO. HY/2012/06
 WIDENING OF FANLING HIGHWAY
 - TAI HANG TO WO HOP SHEK INTERCHANGE



Graphical Presentation of Impact 24-hour TSP Monitoring Results

Project No.: 60307376

Date: Feb-17

Appendix G

Appendix G
Impact Air Quality Monitoring Results

1-hour TSP Monitoring Results at Station AM2
(Fanling Government Secondary School)

Date	Start Time (hh:mm)	1st Hour	2nd Hour	3rd Hour
		Conc. ($\mu\text{g}/\text{m}^3$)	Conc. ($\mu\text{g}/\text{m}^3$)	Conc. ($\mu\text{g}/\text{m}^3$)
3-Jan-17	13:15	72.2	74.1	70.9
9-Jan-17	9:30	72.8	73.1	72.6
14-Jan-17	10:40	74.2	71.5	70.7
20-Jan-17	9:50	66.6	67.2	68.3
26-Jan-17	11:45	73.3	75.1	71.8
		Average	71.6	
		Min	66.6	
		Max	75.1	

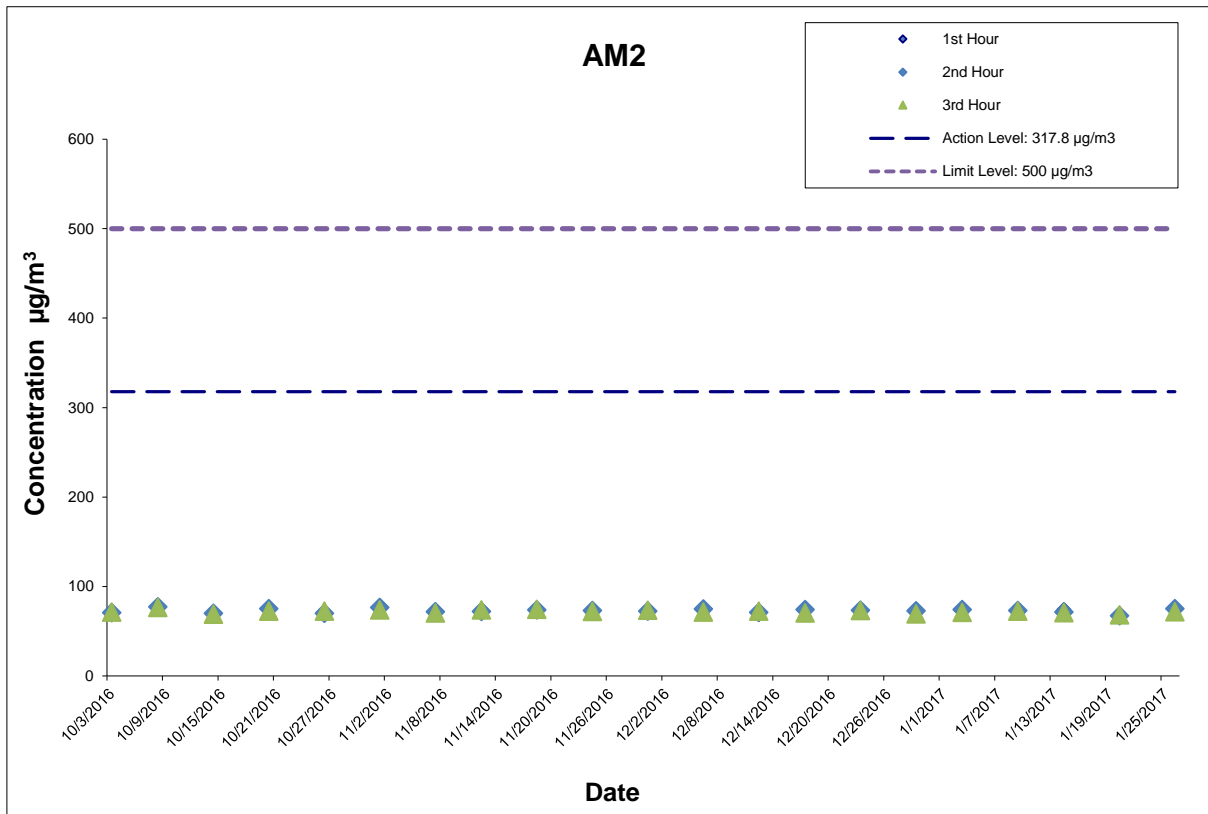

This Drawing has been prepared for the use of AECOM's client. It may not be used, modified, reproduced or relied upon by third parties, except as agreed by AECOM or as required by law. AECOM accepts no responsibility, and denies any liability whatsoever, to any party that uses or relies on this drawing without AECOM's express written consent.

CONTRACT NO. HY/2012/06
 WIDENING OF FANLING HIGHWAY
 - TAI HANG TO WO HOP SHEK INTERCHANGE



Graphical Presentation of Impact 1-hour TSP Monitoring Results

Project No.: 60307376

Date: Feb-17

Appendix G

**APPENDIX H
METEOROLOGICAL DATA FOR THE
REPORTING MONTH**

[Home](#)[What's new](#)[About us](#)[HKO Side Lights](#)[Our Services](#)[Visitors Figures](#)[Press releases](#)[Today's Weather Warnings](#)[Local Weather](#)[Observations](#)[Weather Forecast](#)[Weather Monitoring](#)[Imagery](#)[Computer Forecast](#)[Products](#)[MyObservatory](#)[Met on Map](#)[Tropical Cyclones](#)[Aviation Weather Services](#)[Marine Meteorological Services](#)[Weather Information for Sports](#)[Weather Information for Communities](#)[China Weather](#)[World Weather](#)[Climatological Information Services](#)[> Climate Watch](#)[> Climate Statistics](#)[> Climate Prediction](#)[> Climate Knowledge](#)[> Need More Information?](#)[> Global Climate Services](#)[> Other Useful Links](#)[Climate Forecast](#)[Climate Change](#)[El Nino and La Nina](#)[Earthquakes and Tsunamis](#)[Astronomy, Space Weather and Geomagnetism](#)[Time and Calendar](#)[Radiation Monitoring, Assessment and](#)[Back](#)

Daily Extract of Meteorological Observations , January 2017 - Tai Po

Year Month

Day	Mean Pressure (hPa)	Air Temperature			Mean Dew Point (deg. C)	Mean Relative Humidity (%)	Total Rainfall (mm)	Prevailing Wind Direction (degrees)	Mean Wind Speed (km/h)
		Absolute Daily Max (deg. C)	Mean (deg. C)	Absolute Daily Min (deg. C)					
01	1021.8	22.0	19.2	17.5	15.9	81	***	***	***
02	1020.3	24.7	19.8	16.3	16.4	83	***	***	***
03	1019.7	22.1	19.3	16.6	17.0	87	***	***	***
04	1018.6	23.1#	20.0	17.8#	16.6	81	***	***	***
05	1016.8	24.3	20.4	17.0	17.9	86	***	***	***
06	1015.1	25.4	21.2	17.4	17.9	83	***	***	***
07	1013.8	24.6	21.2	19.6	18.0	82	***	***	***
08	1013.3	26.1#	22.2	18.7#	18.3	79	***	***	***
09	1016.2	22.6	19.8	18.0	16.1	80	***	***	***
10	1018.1	20.9#	19.3	18.2#	16.0	81	***	***	***
11	1018.1	20.3	18.9	17.9	15.8	82	***	***	***
12	1015.8	19.1	17.6	13.4	14.6	82	***	***	***
13	1016.5	15.0	13.5	12.0	10.9	85	***	***	***
14	1018.5	15.3	13.6	12.1	12.5	93	***	***	***
15	1021.0	15.1	13.9	12.9	12.8	93	***	***	***
16	1020.7	17.6	15.2	12.6	12.8	86	***	***	***
17	1021.2	19.0	17.7	16.3	13.8	78	***	***	***
18	1021.3	19.9	18.4	17.4	16.7	90	***	***	***
19	1020.1	23.0	20.3	18.0	18.0	87	***	***	***
20	1022.9	20.0	17.2	14.5	11.0	67	***	***	***
21	1025.5	19.8	16.0	12.4	10.1	69	***	***	***
22	1026.3	19.8	15.0	10.7	7.6	63	***	***	***
23	1025.9	20.1	15.9	12.5	10.8	73	***	***	***
24	1025.6	20.1	17.0	15.4	12.0	73	***	***	***
25	1025.7	21.4	17.8	14.8	13.4	76	***	***	***
26	1024.6	20.5	17.0	14.9	11.7	72	***	***	***
27	1022.8	22.7	17.4	13.6	11.5	70	***	***	***
28	1018.8	19.4	16.8	14.5	13.5	81	***	***	***
29	1016.7	21.6	19.4	17.9	17.7	90	***	***	***
30	1018.2	22.6	20.0	16.8	18.6	92	***	***	***
31	1020.4	17.3	16.3	15.2	14.3	88	***	***	***

*** unavailable

data incomplete

Rainfall measured in increment of 0.5 mm. Amount of < 0.5 mm cannot be detected

[Home](#)[What's new](#)[About us](#)[HKO Side Lights](#)[Our Services](#)[Visitors Figures](#)[Press releases](#)[Today's Weather Warnings](#)[Local Weather](#)[Observations](#)[Weather Forecast](#)[Weather Monitoring](#)[Imagery](#)[Computer Forecast](#)[Products](#)[MyObservatory](#)[Met on Map](#)[Tropical Cyclones](#)[Aviation Weather Services](#)[Marine Meteorological Services](#)[Weather Information for Sports](#)[Weather Information for Communities](#)[China Weather](#)[World Weather](#)[Climatological Information Services](#)[> Climate Watch](#)[> Climate Statistics](#)[> Climate Prediction](#)[> Climate Knowledge](#)[> Need More Information?](#)[> Global Climate Services](#)[> Other Useful Links](#)[Climate Forecast](#)[Climate Change](#)[El Nino and La Nina](#)[Earthquakes and Tsunamis](#)[Astronomy, Space Weather and Geomagnetism](#)[Time and Calendar](#)[Radiation Monitoring, Assessment and](#)[Back](#)

Daily Extract of Meteorological Observations , January 2017 - Tai Mei Tuk

Year Month

Day	Mean Pressure (hPa)	Air Temperature			Mean Dew Point (deg. C)	Mean Relative Humidity (%)	Total Rainfall (mm)	Prevailing Wind Direction (degrees)	Mean Wind Speed (km/h)
		Absolute Daily Max (deg. C)	Mean (deg. C)	Absolute Daily Min (deg. C)					
01	***	22.1#	18.9	17.3#	***	***	0.0	060	13.8
02	***	24.4	19.9	16.9	***	***	0.0	110	7.3
03	***	22.5#	19.3	17.0#	***	***	0.0	090	10.2
04	***	22.9#	19.6	17.3#	***	***	0.0	110	11.0
05	***	24.3#	20.6	17.6#	***	***	0.0	080	3.8
06	***	25.6#	20.9	18.0#	***	***	0.0	070	9.3
07	***	24.5	20.7	18.6	***	***	0.0	070	10.6
08	***	26.7	22.0	19.0	***	***	0.0	250	5.3
09	***	23.1	19.8	18.3	***	***	0.0	100	11.0
10	***	21.2#	19.0	17.7#	***	***	0.0	090	18.7
11	***	20.5#	18.6	17.1#	***	***	0.0	090	15.9
12	***	19.6#	17.6	14.3#	***	***	0.0	040	10.2
13	***	14.6#	13.7	12.9#	***	***	0.5	050	5.2
14	***	15.7#	14.1	12.5#	***	***	1.0	040	9.9
15	***	15.2#	14.1	12.7#	***	***	3.0	040	12.2
16	***	17.0#	15.3	13.0#	***	***	0.5	050	16.9
17	***	19.4#	17.4	15.7#	***	***	0.0	080	15.9
18	***	20.0#	18.4	17.3#	***	***	0.0	050	7.0
19	***	23.9#	20.1	18.0#	***	***	0.0	070	5.7
20	***	22.1	16.8	14.2	***	***	0.0	040	15.9
21	***	20.5	16.1	13.0	***	***	0.0	010	11.0
22	***	20.1	15.5	12.0	***	***	0.0	040	10.0
23	***	19.8#	16.0	12.9#	***	***	0.0	100	13.6
24	***	20.6#	16.7	14.6#	***	***	0.0	100	18.3
25	***	22.6#	17.4	14.7#	***	***	0.0	110	13.2
26	***	20.4#	16.5	13.9#	***	***	0.0	050	13.0
27	***	22.7#	17.0	13.6#	***	***	0.0	050	10.6
28	***	19.6#	16.6	14.8#	***	***	0.0	080	9.4
29	***	22.8#	19.3	17.3#	***	***	3.0	050	10.4
30	***	23.2	19.8	16.4	***	***	0.5	270	9.0
31	***	17.7	15.9	14.3	***	***	0.0	030	13.2

*** unavailable

data incomplete

Rainfall measured in increment of 0.5 mm. Amount of < 0.5 mm cannot be detected

**APPENDIX I
IMPACT DAYTIME CONSTRUCTION NOISE
MONITORING RESULTS AND THEIR
GRAPHICAL PRESENTATION**

Appendix I Impact Daytime Construction Noise Monitoring Results

Location : M2 (West Tai Wo - Free Field)

Day time 07:00-19:00 hrs Normal Weekdays Impact Noise Monitoring Results

Date	Measured Noise Level for 30-min, dB(A)				Limit Level, dB(A)	Exceedance (Y/N)
	Start Time	Leq*	L10*	L90*		
3-Jan-17	14:15	68.1	69.8	65.0	75	N
9-Jan-17	10:15	70.2	71.8	68.3	75	N
20-Jan-17	13:00	68.5	70.0	66.0	75	N
26-Jan-17	13:03	68.8	70.3	66.3	75	N
	Min	68.1	69.8	65.0		
	Max	70.2	71.8	68.3		
	Average	69.0	70.6	66.6		

Location : M3 (Fanling Government Secondary School- Façade)

Day time 07:00-19:00 hrs Normal Weekdays Impact Noise Monitoring Results

Date	Measured Noise Level for 30-min, dB(A)				Limit Level, dB(A)^	Exceedance (Y/N)
	Start Time	Leq	L10	L90		
3-Jan-17	13:20	65.3	66.7	62.1	70	N
9-Jan-17	9:30	64.5	65.7	62.5	65	N
20-Jan-17	9:50	60.6	61.5	57.0	70	N
26-Jan-17	14:05	64.1	65.8	61.9	70	N
	Min	60.6	61.5	57.0		
	Max	65.3	66.7	62.5		
	Average	63.9	65.3	61.3		

* +3dB(A) Façade effect correction included

^ Limit Level of 70dB(A) applies to education institutes while 65dB(A) applies during school examination period.

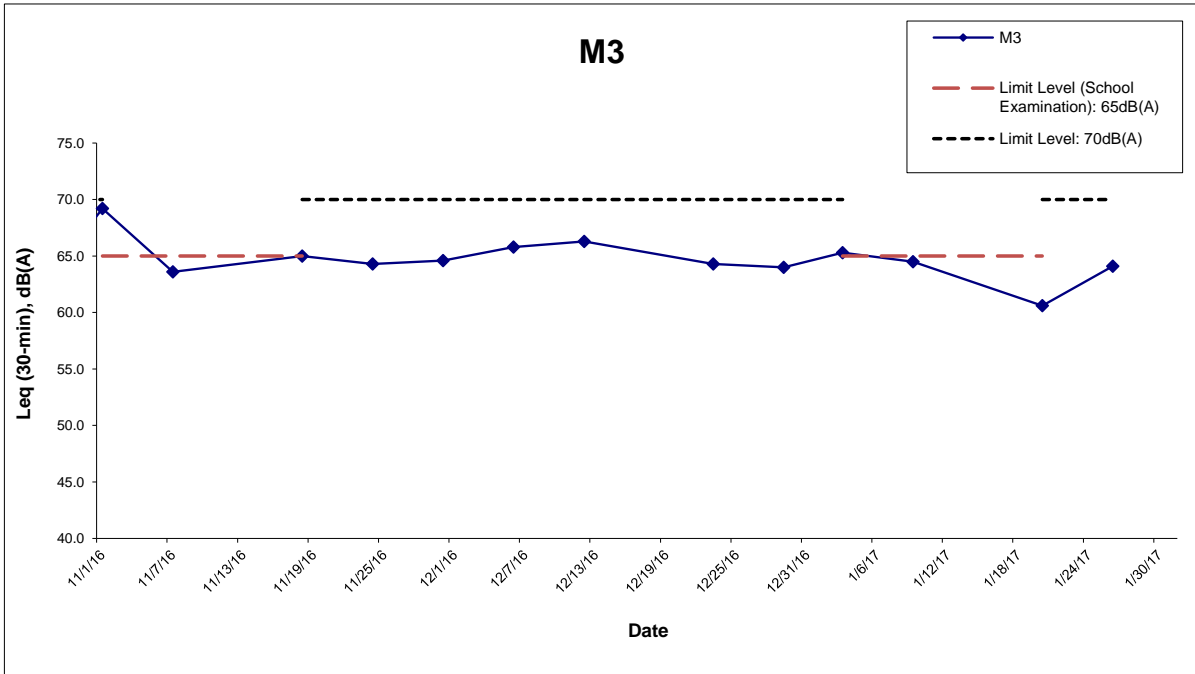
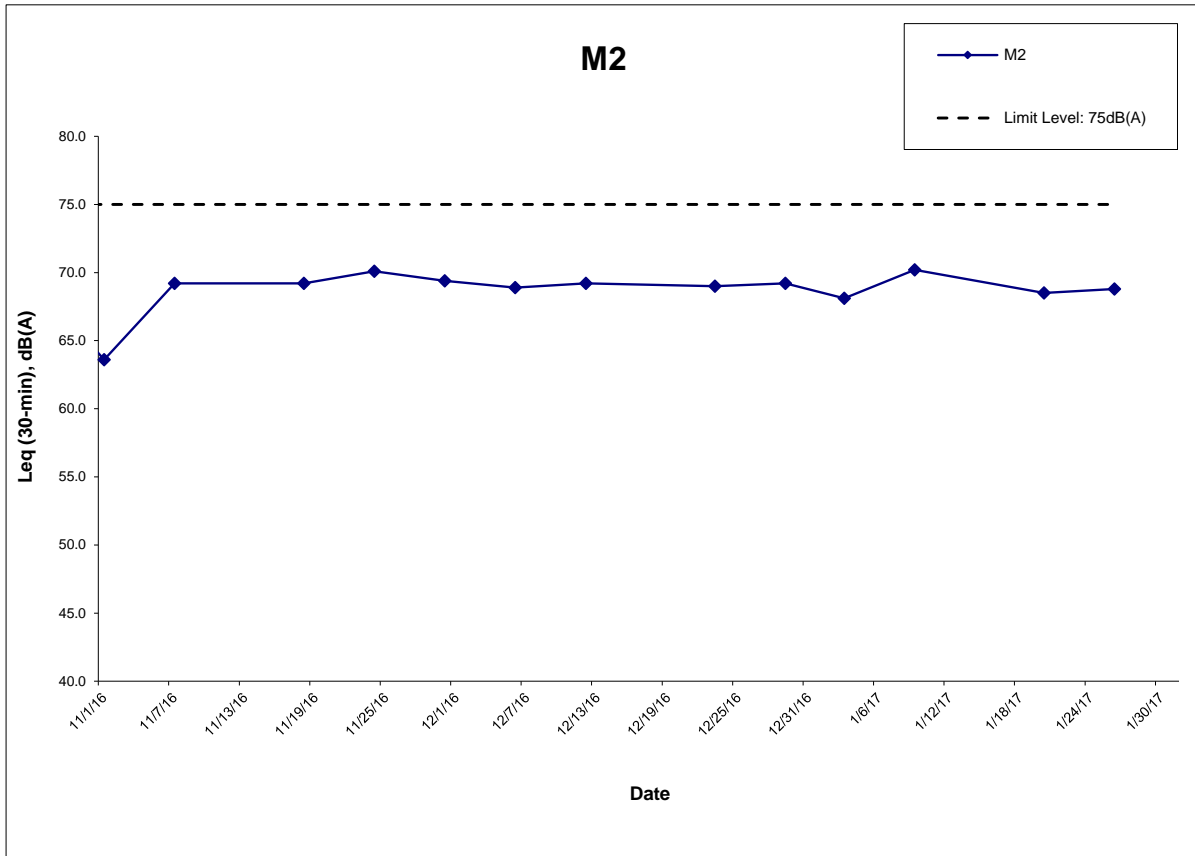

Remark:

^ Limit Level of 70dB(A) applies to education institutes while 65dB(A) applies during school examination period.

This Drawing has been prepared for the use of AECOM's client. It may not be used, modified, reproduced or relied upon by third parties, except as agreed by AECOM or as required by law. AECOM accepts no responsibility, and denies any liability whatsoever, to any party that uses or relies on this drawing without AECOM's express written consent.

CONTRACT NO. HY/2012/06
 WIDENING OF FANLING HIGHWAY
 - TAI HANG TO WO HOP SHEK INTERCHANGE

Graphical Presentation of Impact Daytime Construction Noise
 Monitoring Results

Project No.: 60307376

Date: Feb-17



Appendix I

**APPENDIX J
EVENT ACTION PLAN**

Appendix J – Event Action Plan

Event / Action Plan for Air Quality

Event	Action			
	ET Leader	IEC	ER	Contractor
Action Level				
Exceedance for one sample	<ol style="list-style-type: none"> 1. Identify source; 2. Inform IEC and ER; 3. Repeat measurement to confirm finding; 4. Increase monitoring frequency to daily. 	<ol style="list-style-type: none"> 1. Check monitoring data submitted by ET; 2. Check Contractor's working method. 	<ol style="list-style-type: none"> 1. Notify Contractor. 	<ol style="list-style-type: none"> 1. Rectify any unacceptable practice; 2. Amend working methods if appropriate.
Exceedance for two or more consecutive samples	<ol style="list-style-type: none"> 1. Identify source; 2. Inform IEC and ER; 3. Repeat measurements to confirm findings; 4. Increase monitoring frequency to daily; 5. Discuss with IEC and Contractor on remedial actions required; 6. If exceedance continues, arrange meeting with IEC and ER; 7. If exceedance stops, cease additional monitoring. 	<ol style="list-style-type: none"> 1. Check monitoring data submitted by ET; 2. Check Contractor's working method; 3. Discuss with ET and Contractor on possible remedial measures; 4. Advise the ER on the effectiveness of the proposed remedial measures; 5. Supervise Implementation of remedial measures. 	<ol style="list-style-type: none"> 1. Confirm receipt of notification of failure in writing; 2. Notify Contractor; 3. Ensure remedial measures properly implemented. 	<ol style="list-style-type: none"> 1. Submit proposals for remedial actions to IEC within 3 working days of notification; 2. Implement the agreed proposals; 3. Amend proposal if appropriate.

Event / Action Plan for Air Quality

Event Action Level	Action			
	ET Leader	IEC	ER	Contractor
Limit Level				
Exceedance for one sample	<ol style="list-style-type: none"> 1. Identify source; 2. Inform IEC, ER, Contractor and EPD; 3. Repeat measurement to confirm finding; 4. Increase monitoring frequency to daily; 5. Assess effectiveness of Contractor's remedial actions and keep IEC, EPD and ER informed of the results. 	<ol style="list-style-type: none"> 1. Check monitoring data submitted by ET; 2. Check Contractor's working method; 3. Discuss with ET and Contractor on possible remedial measures; 4. Advise ER on the effectiveness of the proposed remedial measures; 5. Supervise implementation of remedial measures. 	<ol style="list-style-type: none"> 1. Confirm receipt of notification of exceedance in writing; 2. Notify Contractor; 3. Ensure remedial measures properly implemented. 	<ol style="list-style-type: none"> 1. Take immediate action to avoid further exceedance; 2. Submit proposals for remedial actions to IEC within 3 working days of notification; 3. Implement the agreed proposals; 4. Amend proposal if appropriate.
Exceedance for two or more consecutive samples	<ol style="list-style-type: none"> 1. Notify IEC, ER, Contractor and EPD; 2. Identify source; 3. Repeat measurement to confirm findings; 4. Increase frequency to daily; 5. Analyse Contractor's working procedures to determine possible mitigation to be; 6. Arrange meeting with IEC and ER to discuss the remedial actions to be taken; 7. Assess effectiveness of Contractor's remedial actions and keep IEC, EPD and ER informed of the results; 8. If exceedance stops, cease additional monitoring. 	<ol style="list-style-type: none"> 1. Discuss amongst ER, ET, and Contractor on the potential remedial actions; 2. Review Contractor's remedial actions whenever necessary to assure their effectiveness and advise ER accordingly; 3. Supervise the implementation of remedial measures. 	<ol style="list-style-type: none"> 1. Confirm receipt of notification of exceedance in writing; 2. Notify Contractor; 3. In consultation with the IEC, agree with the Contractor on the remedial measures to be implemented; 4. Ensure remedial measures properly implemented; 5. If exceedance continues, consider what portion of the work is responsible and instruct the Contractor to stop that portion of work until the exceedance is abated. 	<ol style="list-style-type: none"> 1. Take immediate action to avoid further exceedance; 2. Submit proposals for remedial actions to IEC within 3 working days of notification; 3. Implement the agreed proposals; 4. Resubmit proposals if problem still not under control; 5. Stop the relevant portion of works as determined by ER until the exceedance is abated.

Event / Action Plan for Noise Impact

Event Limit Level	Action			
	ET Leader	IEC	ER	Contractor
Action Level	<ol style="list-style-type: none"> 1. Notify IEC and the Contractor. 2. Carry out investigation. 3. Report the results of investigation to IEC and the Contractor. 4. Discuss with the Contractor and formulate remedial measures. 5. Increase monitoring frequency to check mitigation effectiveness. 	<ol style="list-style-type: none"> 1. Review with analysed results submitted by ET. 2. Review the proposed remedial measures by the Contractor and advise ER accordingly. 3. Supervise the implement of remedial measures. 	<ol style="list-style-type: none"> 1. Confirm receipt of notification of failure in writing. 2. Notify the Contractor. 3. Require the Contractor to propose remedial measures for the analysed noise problem. 4. Ensure remedial measures are properly implemented. 	<ol style="list-style-type: none"> 1. Submit noise mitigation proposals to IEC. 2. Implement noise mitigation proposals.
Limit Level	<ol style="list-style-type: none"> 1. Notify, IEC, ER, EPD and the Contractor. 2. Identify the source. 3. Repeat measurement to confirm findings. 4. Increase monitoring frequency. 5. Carry out analysis of Contractor's working procedures to determine possible mitigation to be implemented. 6. Inform IEC, ER, and EPD the causes & actions taken for the exceedances. 7. Assess effectiveness of the Contractor's remedial actions and keep IEC, EPD and ER informed of the results. 8. If exceedance stops, cease additional monitoring. 	<ol style="list-style-type: none"> 1. Discuss amongst ER, ET Leader and the Contractor on the potential remedial actions. 2. Review the Contractor's remedial actions whenever necessary to assure their effectiveness and advise ER accordingly. 3. Supervise the implementation of remedial measures. 	<ol style="list-style-type: none"> 1. Confirm receipt of notification of failure in writing. 2. Notify the Contractor. 3. Require the Contractor to propose remedial measures for the analysed noise problem. 4. Ensure remedial measures are properly implemented. 5. If exceedance continues, consider what activity of the work is responsible and instruct the Contractor to stop that activity of work until the exceedance is abated. 	<ol style="list-style-type: none"> 1. Take immediate action to avoid further exceedance. 2. Submit proposals for remedial actions to IEC within 3 working days of notification. 3. Implement the agreed proposals. 4. Resubmit proposals if problem still not under control. 5. Stop the relevant activity of works as determined by the ER until the exceedance is abated.

**APPENDIX K
SITE INSPECTION SUMMARIES**

Site Inspection Summary

Inspection Information

Contract No.	HY/2012/06
Date:	3 January 2017
Time:	14:00
Inspection No.:	164

Non-compliance

Nil

Observations

	<p><u>Follow-up Observation(s)</u></p> <ol style="list-style-type: none"> Adequate water was sprayed on the surface of breaking operation observed at SA340. (Closed) Stagnant water found at SA340 was removed. (Closed) Construction wastes found near existing vegetation at SA340 were removed. (Closed) <p><u>New Observation(s)</u></p> <ol style="list-style-type: none"> Construction materials and wastes were found near existing vegetation at SA320. The Contractor should remove the construction materials and wastes to keep the site clean and tidy. General refuse was found scattered on ground at SA320. The Contractor should remove the general refuse and keep the site clean and tidy. Chemical container without drip tray was found at SA320. The Contractor should provide secondary containment to avoid potential leakage. <p><u>Reminder (s)</u></p> <p>Nil.</p>
--	---

Remarks

Nil

	Name	Signature	Date
Prepared by	Sammi Lam		3 January 2017
Checked by	Y W Fung	/	3 January 2017

Site Inspection Summary

Inspection Information

Contract No.	HY/2012/06
Date:	10 January 2017
Time:	14:00
Inspection No.:	165

Non-compliance

Nil

Observations

	<p><u>Follow-up Observation(s)</u></p> <ol style="list-style-type: none"> Construction materials and wastes found near existing vegetation at SA320 were removed. (Closed) General refuse found scattered on ground at SA320 was removed. (Closed) Chemical container without drip tray found at SA320 was provided with secondary containment. (Closed) <p><u>New Observation(s)</u></p> <ol style="list-style-type: none"> Water sprayed on open site areas was found inadequate at SA324 and SA320. The Contractor should spray the open site areas with adequate water to prevent windblown dust emission. Construction wastes and materials were found scattered on ground at SA325 and SA326. The Contractor should remove the construction wastes and materials to keep the site clean and tidy. <p><u>Reminder (s)</u></p> <p>Nil.</p>
--	---

Remarks

Nil

	Name	Signature	Date
Prepared by	Sammi Lam		10 January 2017
Checked by	Y W Fung	/	10 January 2017

Site Inspection Summary

Inspection Information

Contract No.	HY/2012/06
Date:	19 January 2017
Time:	14:00
Inspection No.:	166

Non-compliance

Nil

Observations

	<p><u>Follow-up Observation(s)</u></p> <ol style="list-style-type: none"> Adequate water was sprayed on open site areas at SA324 and SA320. (Closed) Construction wastes and materials found scattered on ground at SA325 and SA326 were removed. (Closed) <p><u>New Observation(s)</u></p> <ol style="list-style-type: none"> Construction wastes were found scattered on ground at SA326. The Contractor should remove the construction wastes to keep the site clean and tidy. Public access road at SA328 was observed dusty. The Contractor should provide sufficient measures to keep the public access road clear of dusty materials. <p><u>Reminder (s)</u></p> <p>Nil.</p>
--	---

Remarks

Nil

	Name	Signature	Date
Prepared by	Sammi Lam		19 January 2017
Checked by	Y W Fung	/	19 January 2017

Site Inspection Summary

Inspection Information

Contract No.	HY/2012/06
Date:	24 January 2017
Time:	14:00
Inspection No.:	167

Non-compliance

Nil

Observations

	<p><u>Follow-up Observation(s)</u></p> <ol style="list-style-type: none"> Construction wastes found scattered on ground at SA326 were removed. (Closed) Dusty materials observed along the public access road at SA328 were cleared. (Closed) <p><u>New Observation(s)</u></p> <ol style="list-style-type: none"> Silts and debris were found near the entrance of drainage system at NB76. The Contractor should remove the sandy materials and implement measures to prevent silts and debris from entering the drainage system. Exposed stockpile of dusty materials were found at SA340. The Contractor should cover the stockpile entirely by impervious sheeting. Stagnant water was found at SA340. The Contractor should remove the water or apply larvicidal oil to prevent mosquito breeding. <p><u>Reminder (s)</u></p> <p>Nil.</p>
--	---

Remarks

Nil

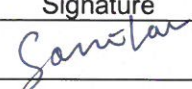
	Name	Signature	Date
Prepared by	Sammi Lam		24 January 2017
Checked by	Y W Fung	/	24 January 2017

**APPENDIX L
STATISTICS ON COMPLAINTS,
NOTIFICATION OF SUMMONS AND
SUCCESSFUL PROSECUTIONS**

Appendix L

Statistics on Complaints, Notifications of Summons and Successful Prosecutions

	Date Received	Subject	Status	Total no. followed up by the ET this month	Total no. followed up by the ET since project commencement
Environmental complaints	19 December 2013	EPD referred a complaint from Lot no. 116 of Fui Sha Wai at Tai Hang of Tai Po which is concerned about the construction noise and diesel-like smell generated from construction activities nearby which caused nuisance and health problems on 19 December 2013 morning.	Closed	1	6
	24 February 2014	EPD referred an air-and-odour complaint on 24 February 2014. The complainant complained about the construction site located near the bus stop in Fui Sha Wai, Tai Hang, Tai Wo Service Road West. When construction works were carried out, odour, white smoke and dust were generated. The complainant asked for follow-up actions.	Closed		
	23 October 2014	EPD referred an air complaint on 24 October 2014. A resident complained against the excavation works of Tai Wo Service Road West between Nam Wah Po & Tai Hang Tsuen, which have piled up high stockpiles, causing serious dust nuisance to his house. The resident also complained that the stockpiles have not been	Closed		

Date Received	Subject	Status	Total no. followed up by the ET this month	Total no. followed up by the ET since project commencement
	covered and watered properly. He now requires the EPD to follow up. The location of complaint is near Lamppost Location EB5717.			
31 December 2014	EPD referred a water complaint on 31 December 2014. The complainant complained about the muddy river outside Tai Hang Village Office on 29 December 2014. It was suspected that the muddy water was discharged from the construction works of the Project. He required the EPD to follow up.	Closed		
25 March 2015	EPD referred a water complaint on 25 March 2015. The complainant complained about the generation of the smell of gasoline from the Widening of Fanling Highway construction site on Tai Wo Service Road West, causing serious nuisance to nearby houses. The situation has continued for a few weeks and she asked the EPD to follow up as soon as possible.	Closed		

	Date Received	Subject	Status	Total no. followed up by the ET this month	Total no. followed up by the ET since project commencement
	5 January 2017 (Referred by the Contractor on 13 January 2017)	<p>A complaint was received by the 1823 enquiry and complaint hotline on 5 January 2017. The complaint was referred to the Environmental Team by the Contractor on 13 January 2017.</p> <p>The complainant complained against the dust emission generated by the Widening of Fanling Highway construction site on Tai Wo Service Road West near Tai Hang Village.</p> <p>The complainant also complained that Highway Department did not conduct road surface cleansing, which affects residents' health. He/she now requires the Highway Department to follow up.</p>	Closed		
Notification of summons	-	-	-	0	0
Successful Prosecutions	-	-	-	0	0

**APPENDIX M
COMPLAINT INVESTIGATION REPORT**

CONTRACT NO. HY/2012/06
Widening of Fanling Highway
Between Tai Hang and Wo Hop Shek Interchange (Stage 2)

ENVIRONMENTAL COMPLAINT ACTION FORM

Environmental Enquiry No.: EC-06
(Related Previous Enquiry NO.: --)

COMPLAINT DETAILS

Date Received	13 January 2017
Parameter	* Air / Noise / Water / Waste / Landscape
Enquirer's Details	
Name	Not disclosed
Contact Tel No.	Not disclosed
Address	Not disclosed

FOLLOW-UP ACTION

First Contact with the Complaint by	* Telephone / Site Visit / Referral from EPD / Referral from the 1823 enquiry and complaint hotline
Date of the First Contact	5 January 2017
<p>Details of Complaint:</p> <p>The 1823 enquiry and complaint hotline referred a complaint on 13 January 2017.</p> <p>A complainant complained against the dust emission generated by the Widening of Fanling Highway construction site on Tai Wo Service Road West near Tai Hang Village.</p> <p>The complainant also complained that Highway Department did not conduct road surface cleansing, which affects residents' health. He/she now requires the Highway Department to follow up.</p>	

Investigation and Findings :

According to the Contractor (China State Construction Engineering (HK) Ltd.), road surface cleansing works along Tai Wo Service Road West and its branch roads (Figure 1) were carried out immediately after receiving the complaint on 5 January 2017.

Following the receipt of the complaint, the Contractor has enhanced water bowser operation frequency from once a day to four times a day, in which cleansing works are scheduled twice in the morning and twice in the afternoon. In addition, the Contractor would further increase the frequency of road cleansing work if dusty condition was observed.

According to the Contractor, construction activities near Tai Wo Service Road West during 2nd to 6th January 2017 include pipe laying, excavation, backfilling, concreting work, formworking, steel bar fixing and noise barrier installation. The construction work will inevitably lead to dust emission, which are mainly excavation, concreting work and material handling.

The Contractor implemented dust suppression measures at the area including:

- Daily road surface cleansing (Figure 2).
- Water sprays for unpaved haul roads and active construction areas to suppress dust generation (Figure 3).
- Wheel washing facilities for every vehicle exit point to remove any dusty materials from vehicles body and wheels before leaving the construction site (Figure 4).
- Water spays for dust emission construction activities (Figure 5).

The Contractor was reminded to carry out mitigation measures to prevent recurrence of air-related complaints:

- Spraying active construction areas with sufficient water for efficient dust suppression.
- Covering exposed stockpiles to prevent windblown dust emission.
- Increasing the frequency of road surface cleansing if necessary.

The complaint is likely to be project-related.

The Contractor is advised to implement the mitigation measures as stated in "Recommended Mitigation Measures".

Exceedance Associated with Site
Activity to

* No Exceedance / ~~Action / Limit~~

Recommended Mitigation Measures:

- 1) Ensure all dust suppression measures are properly implemented to minimize fugitive dust generation;
- 2) Review the adequacy and effectiveness of dust suppression measures implemented for different construction activities and conditions regularly;
- 3) Foster better public relations with the sensitive receivers and complainants nearby; and
- 4) Increase the frequency of road surface cleansing if necessary.

* Delete where inappropriate

MONITORING

Ad hoc Monitoring undertaken	* Yes / No

* Delete where inappropriate

Prepared by: Y W Fung

Designation: Environmental Team Leader

Signature:  _____

Date: 16 January 2017

Figure 1 – Road Surface Cleansing Route

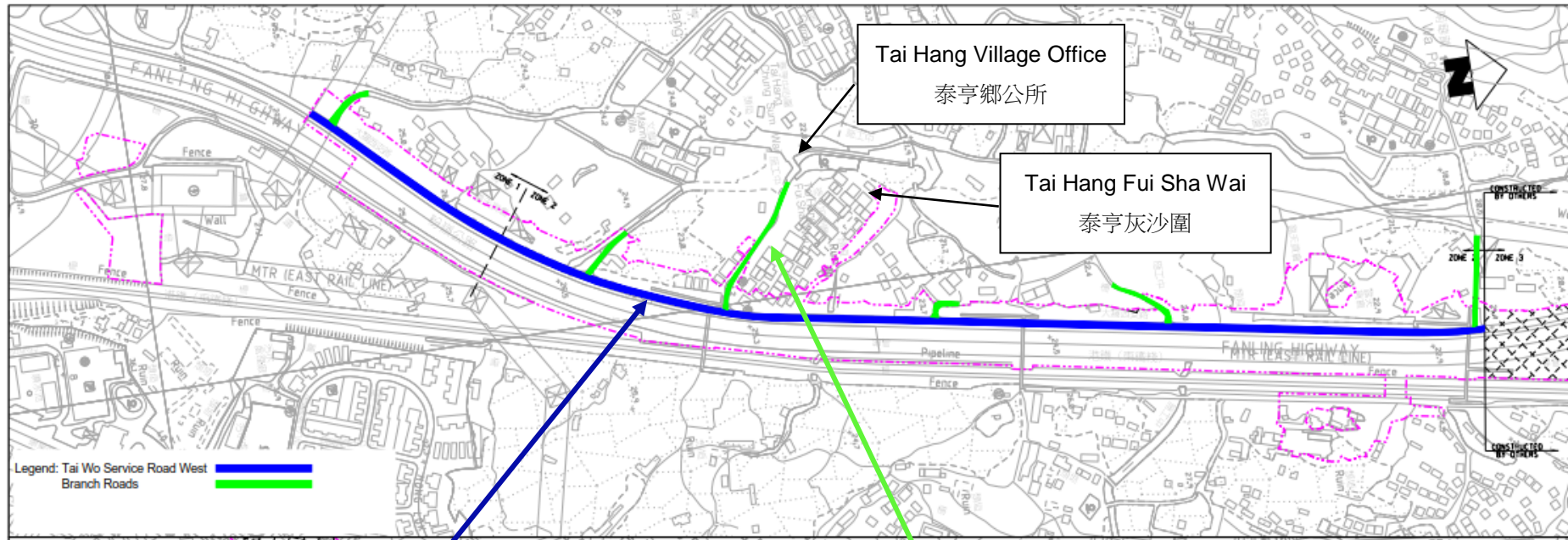

Road surface cleansing along Tai Wo Service Road West



Road surface cleansing along branch roads



Figure 2 – Road Surface Cleansing



Figure 3 – Water Spray for Active Construction Area



Figure 4 – Wheel Washing Facility at Exit Point



Figure 5 – Water Spray for Dust Emission Construction Activity

